

Creations that
give shape to
silence.

*Creaciones
que dan forma
al silencio.*



 HARMONIUM

www.harmonium.design

INDEX *_ÍNDICE*

1 / CORPORATE *_CORPORATIVO*

Who we are <i>_Sobre nosotros</i>	5
Our team <i>_Nuestro equipo</i>	6

2 / TECHNICAL SECTION *_PARTE TÉCNICA*

Technology <i>_Tecnología</i>	8
Safe and sustainable <i>_Seguros y sostenibles</i>	10
Technical data <i>_Datos técnicos</i>	12
Colors <i>_Colores</i>	14
Design and projects <i>_Diseño y proyectos</i>	16

3 / PRODUCTS *_PRODUCTOS*

CEILINGS *_TECHOS*

SKYLINE system <i>_Sistema SKYLINE</i>	20
ONA system <i>_Sistema ONA</i>	28
Baffle systems <i>_Sistemas de baffles</i>	40
Drop ceilings <i>_Techos registrables</i>	44
Acoustic Islands <i>_Islas acústicas</i>	52

WALL COVERINGS *_REVESTIMIENTOS*

Wall coverings <i>_Revestimientos</i>	64
---------------------------------------	----

EQUIPMENT *_EQUIPAMIENTO*

Dividers <i>_Separadores</i>	78
------------------------------	----

CREATIONS *_CREACIONES*

Ceiling creations <i>_Creaciones para techo</i>	92
Wall creations <i>_Creaciones para pared</i>	98
Decorative creations <i>_Creaciones decorativas</i>	104



Who we are / *Sobre nosotros*

At **HARMONIUM**,
we listen to the
world to design
silence.

*En HARMONIUM,
escuchamos el
mundo para
diseñar silencio.*

We are the company that helps bring designers' ideas to life in the physical world.

We ensure that technical limitations are not a barrier and that projects sound as good as they look. Our goal is to become the industry benchmark in decorative acoustic solutions.

We make sure that acoustics are not an obstacle, but rather a tool that enhances the design and fits perfectly with the concept of each project.

We never compromise on aesthetics or functionality in our solutions. We are driven by our commitment to engineering comfort through acoustics.

We believe that, in order to improve the experience of those who inhabit a space designed to last, it is essential to enhance and strengthen creativity. Only then can a sustainable future be achieved.

Everything we do is guided by a clear principle: silence that empowers ideas.

Somos la empresa que ayuda a llevar las ideas de los diseñadores al mundo físico.

Nos aseguramos de que lo técnico no sea un límite y de que los proyectos suenen tan bien como se ven. Nuestro objetivo es convertirnos en el referente de la industria en soluciones acústicas decorativas.

Nos encargamos de que la acústica no sea un obstáculo, sino una herramienta que enriquezca el diseño, que encaje perfectamente con el concepto de cada proyecto.

Defendemos el no sacrificio de la estética y la funcionalidad en nuestras soluciones. Nos impulsa nuestro compromiso con la ingeniería del confort a través de la acústica.

Creemos que, para mejorar la experiencia de quienes habitan un espacio pensado para perdurar, es fundamental potenciar y fortalecer la creatividad. Solo así se logra un futuro sostenible.

Todo lo que hacemos está guiado por un principio claro: silencio que fortalece ideas.

At **HARMONIUM**
innovation is our
essence.

*En HARMONIUM,
innovar es nuestra
esencia.*

The values that define us come to life through the people who make up our team.

Our diverse team is united by a passion for innovation and sustainability. Our designers bring different cultural influences and an artistic touch to create functional and elegant designs. Led by experienced acoustic engineers, we strive to deliver exceptional acoustic performance. Our sustainability experts integrate eco-friendly practices into our development processes.

Through collaboration, we break down barriers and shape the future of sound and design.

Los valores que nos definen cobran vida a través de las personas que forman nuestro equipo.

Nuestro equipo diverso está unido con pasión por la innovación y la sostenibilidad.

Nuestros diseñadores aportan diferentes influencias culturales y un toque artístico para crear diseños funcionales y elegantes. Liderados por ingenieros acústicos experimentados, sobresalimos en ofrecer un rendimiento acústico sin igual. Nuestros expertos en sostenibilidad integran prácticas ecológicas en nuestros procesos de desarrollo.

A través de la colaboración, rompemos barreras y moldeamos el futuro del sonido y el diseño.



CLARA SULLÀ
Sullà Studio
Spain_España



NEREA ORENES
Architect
Germany_Alemania



LAURA JUNCO CAÑEDO
Absotec
Spain_España



ELENA MAS PARRÉS
Interior Designer
Spain_España



ALBERT SCHUSTER
Moja Design
Germany_Alemania



MANUEL TABORGA
CEO & Sound Ambassador
Chile_Chile



DANIEL ZAHONERO
Sustainability Director
Spain_España



SUSANA RODRÍGUEZ LORENTE
Interior Landscaper
Spain_España



ROBERTO FERRETE
Building engineer
Spain_España



VÍCTOR PLAZA
Industrial Designer
Spain_España



JAVIER ORTÍZ
Production Manager
Spain_España



CARMEN ZAHONERO
Marketing Manager
Spain_España

At **HARMONIUM**
the future is sustainable
and performance is
impeccable.

*En **HARMONIUM**,
el futuro es sostenible
y el rendimiento
impeccable.*

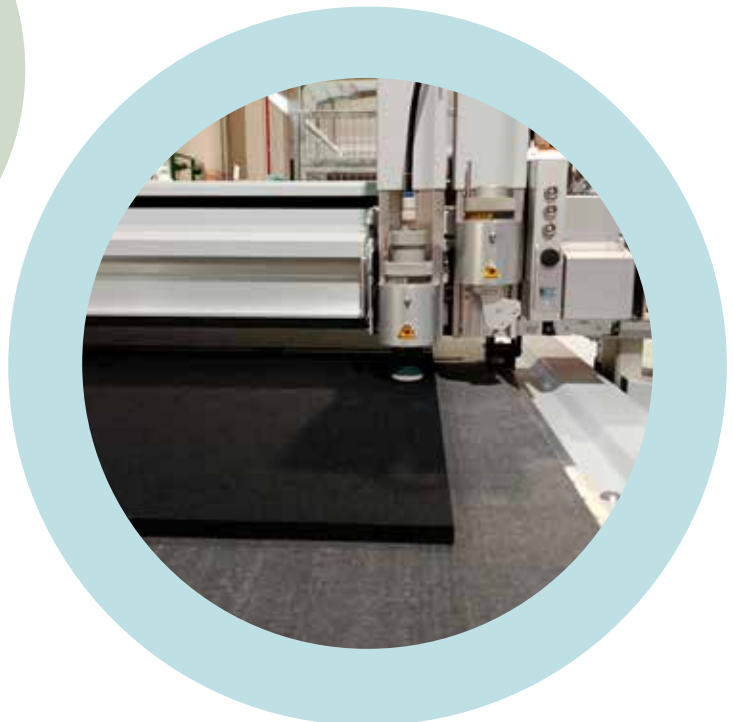
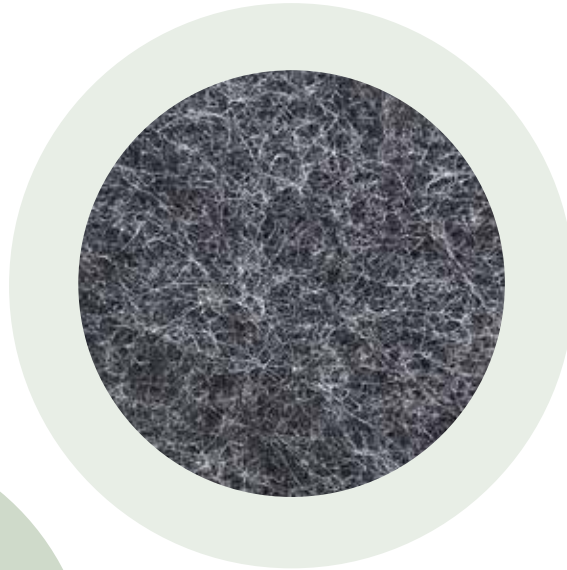
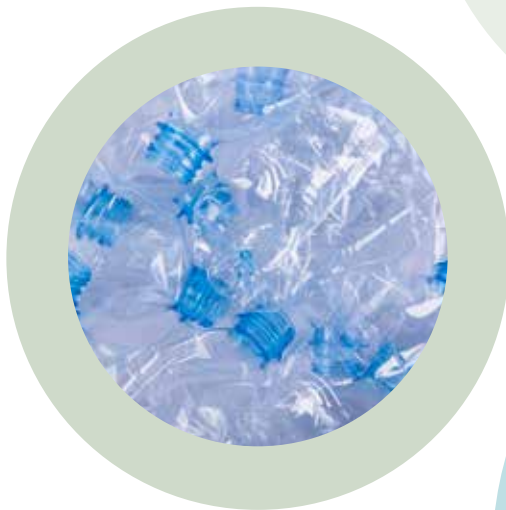

We believe the future lies in the harmony between what we create and the world around us.

At Harmonium®, we have developed the Harmonize Process, an advanced multi-needle punching reinforcement process that increases panel stability and prevents deformation over time, enhances flexural strength and ensures safer installation with a longer panel life cycle—elevating the acoustic experience of any space.

Our acoustic panel is manufactured from **100 % recyclable PET polyester fiber, with a minimum of 75 % certified post-consumer recycled content** in each panel, reaffirming our commitment to sustainability and environmental responsibility.

Its design optimizes installation time and reduces labor costs, making the installation process easier and accelerating delivery timelines.

Creemos que el futuro está en la armonía entre lo que creamos y el mundo que nos rodea.

En Harmonium® hemos desarrollado Harmonize Process, un proceso avanzado de refuerzo por múltiple punzonado que aumenta la estabilidad del panel y evita deformaciones con el tiempo, mejora la resistencia a la flexión y garantiza una instalación más segura con un ciclo de vida del panel más duradero, elevando la experiencia sonora de cualquier espacio.

*Nuestro panel acústico está fabricado con fibra de PET **100 % poliéster reciclable, con un mínimo del 75 % de contenido reciclado postconsumo certificado** en cada plancha, reafirmando nuestro compromiso con la sostenibilidad y el medioambiente.*

Su diseño optimiza los tiempos de montaje y reduce los costes de mano de obra.



Harmonium[®] acoustic panels are fire-classified (ASTM E84 Class A / EN 13501 **B-s1d0**), do not emit harmful substances, ensuring healthy and safe environments.

All this is backed by our **Harmonium**[®] **technology**, which guarantees maximum quality, performance and adaptability for each of your projects.

Each **Harmonium**[®] **PET** panel helps prevent 6.2 kg of plastics from ending up in the oceans. Each **Harmonium**[®] **PET** panel gives new life to 205 plastic bottles, transforming waste into sustainable design: 60 recycled bottles per m².

*Los paneles acústicos de **Harmonium**[®] son ignífugos (ASTM E84 Clase A / EN 13501 **B-s1d0**), no emiten sustancias nocivas, garantizando entornos saludables y seguros.*

*Todo esto respaldado por nuestra **tecnología Harmonium**[®], que garantiza máxima calidad, rendimiento y adaptabilidad para cada uno de tus proyectos.*

*Cada panel de **PET Harmonium**[®] ayuda a evitar que 6.2 kg de plásticos acaben en los océanos. Cada plancha de **PET Harmonium**[®] da una nueva vida a 205 botellas de plástico, transformando residuos en diseño sostenible: 60 botellas recicladas por cada m².*

At **HARMONIUM**,
we turn waste into
the future.

*En **HARMONIUM**,
convertimos
residuos en futuro.*



SOUND ABSORPTION CHART

Performance comparison according to the type of installation (air gap)

TABLA DE ABSORCIÓN ACÚSTICA

Comparativa de rendimiento según el tipo de instalación (cámara de aire)

TYPE OF INSTALLATION TIPO DE INSTALACIÓN	TYPE A TIPO A	E 50 / 50 mm	E 100 / 100 mm	E 150 / 150 mm	E 200 / 200 mm
FREQUENCY (Hz) / FRECUENCIA (Hz)	Absorption coefficient, α_s / Coeficiente de absorción, α_s				
α_m	0,48	0,64	0,75	0,80	0,77
NRC	0,40	0,70	0,80	0,85	0,80
SAA	0,39	0,69	0,82	0,87	0,82
α_w	0,25	0,50	0,70	0,90	0,90

α_m Mean sound absorption coefficient / Coeficiente medio de absorción acústica.

NRC Noise Reduction Coefficient. Average sound absorption value / Noise Reduction Coefficient. Valor promedio de absorción sonora

SAA Sound Absorption Average according to ASTM / Media de absorción según ASTM

α_w Weighted sound absorption coefficient (ISO 11654) / Coeficiente de absorción acústica ponderado (ISO 11654)

SOUND ABSORPTION COEFFICIENT

Analysis by frequency and type of acoustic panel installed

COEFICIENTE DE ABSORCIÓN ACÚSTICA

Análisis por frecuencia y tipo de panel acústico instalado

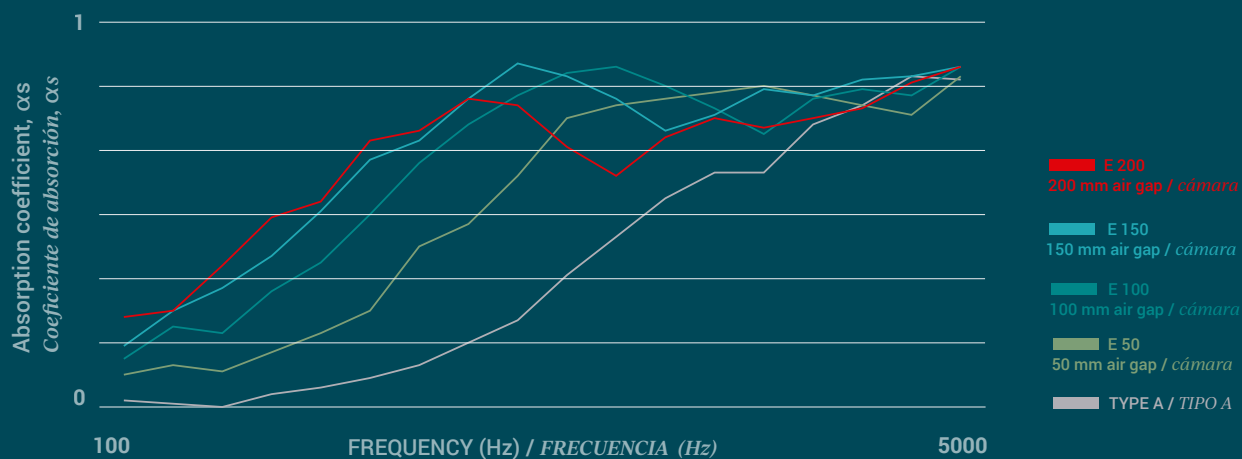



PANEL DIMENSIONS

RAW: 1220 x 2800 x 12 mm

Flawless: 1200 x 2780 x 12mm

Please ask for customised dimensions.

MEDIDAS DE LOS PANELES

Panel en bruto: 1220 x 2800 x 12 mm

Panel rectificado: 1200 x 2780 x 12 mm

Consultar medidas personalizadas.

* Harmonium® panels are made from 75 % post-consumer recycled PET, underlining our commitment to sustainability. As a result, fibres of a different colour to the one selected may occasionally be found. This unique feature confirms the authenticity of the recycled material and does not affect the quality or performance of the product.

** La composición de los paneles Harmonium® contiene un 75 % de PET reciclable postconsumo, lo que subraya nuestro compromiso sostenible. Por ello, es posible encontrar ocasionalmente alguna fibra de color diferente al seleccionado. Esta singularidad confirma la honestidad del material reciclado y no afecta a la calidad ni a las prestaciones del producto.*



01 - POLAR



02 - IVORY



03 - SAND

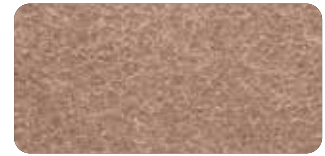

04 - HAZELNUT



05 - ELEPHANT



06 - PUMICE



07 - ARCTIC



08 - GRAPHITE



09 - ANTHRACITE



10 - ONYX



11 - JADE



12 - EVERGREEN



13 - IGUANA



14 - SPEARMINT



15 - AZURE



16 - LAZULI



17 - OBSIDIAN



18 - SAKURA



19 - POMELO

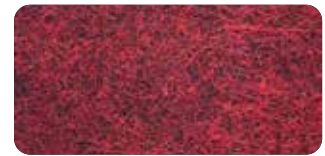

20 - LAVA



21 - TERRACOTTA



22 - SUNBEAM

At **HARMONIUM**
design guides
every solution.

*En HARMONIUM,
el diseño guía
cada solución.*

At Harmonium, we offer customised acoustics that fit the unique concept and style of each project.

We work closely with interior designers, decorators, architectural firms and office furniture suppliers, creating acoustic panels that complement the harmony of the designed space.

We take care of the acoustics while you focus on creating. We believe that an acoustic problem can be turned into a design opportunity, which is why we focus on creating decorative acoustic solutions tailored to your ideas.

En Harmonium ofrecemos acústica personalizada que se ajusta al concepto y estilo único de cada proyecto.

Trabajamos codo a codo con diseñadores de interiores y decoradores, estudios de arquitectura y proveedores de mobiliario de oficina, creando paneles acústicos que complementan la armonía del espacio proyectado.

Nos encargamos de la acústica mientras tú te concentras en crear. Creemos que un problema de acústica se puede convertir en una oportunidad de diseño, por eso nos centramos en crear soluciones acústicas decorativas a medida de tus ideas.

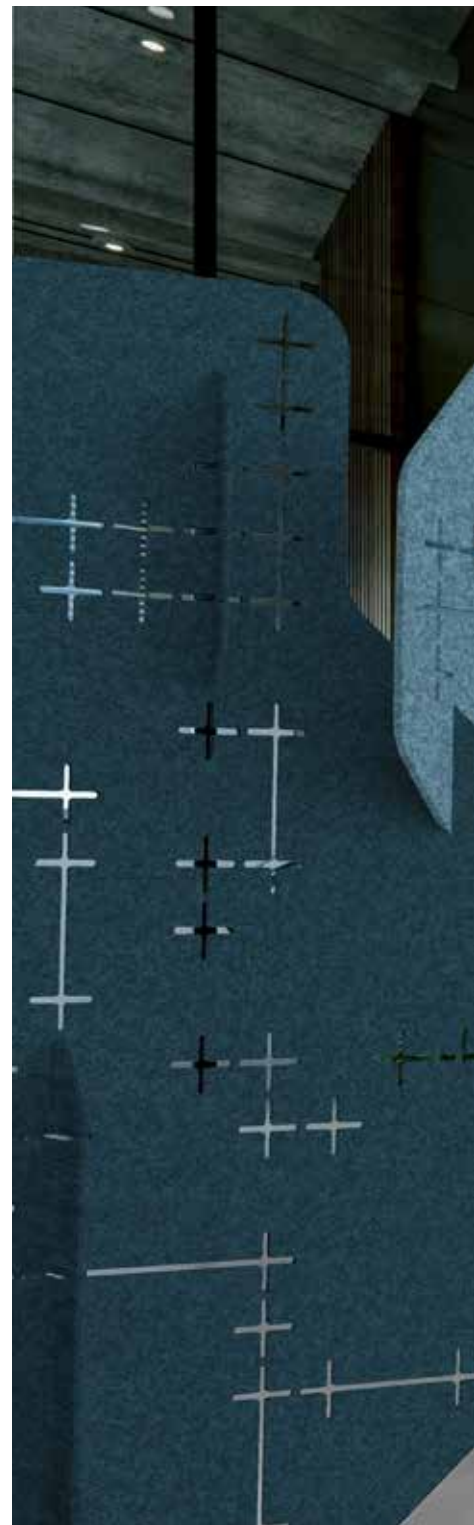



CEILINGS

TECHOS

The ceiling that silences,
inspires and harmonises.

*El techo que silencia,
inspira y armoniza.*



Elegant lines that give
rhythm to silence.

*Líneas elegantes que dan
ritmo al silencio.*

SKYLINE system *Sistema SKYLINE*

The **SKYLINE system** elevates acoustic design with slender slats that create visual rhythms and unique architectural depth. Their recyclable PET composition provides sustainability without compromising elegance. Modular geometries allow for the creation of continuous ceilings full of texture and harmony. A solution that transforms the light, sound and aesthetics of the space with a sophisticated presence.

*El **sistema SKYLINE** eleva el diseño acústico con lamas esbeltas que generan ritmos visuales y una profundidad arquitectónica única. Su composición en PET reciclable aporta sostenibilidad sin renunciar a la elegancia. Las geometrías modulares permiten crear techos continuos llenos de textura y armonía. Una solución que transforma la luz, el sonido y la estética del espacio con una presencia sofisticada.*





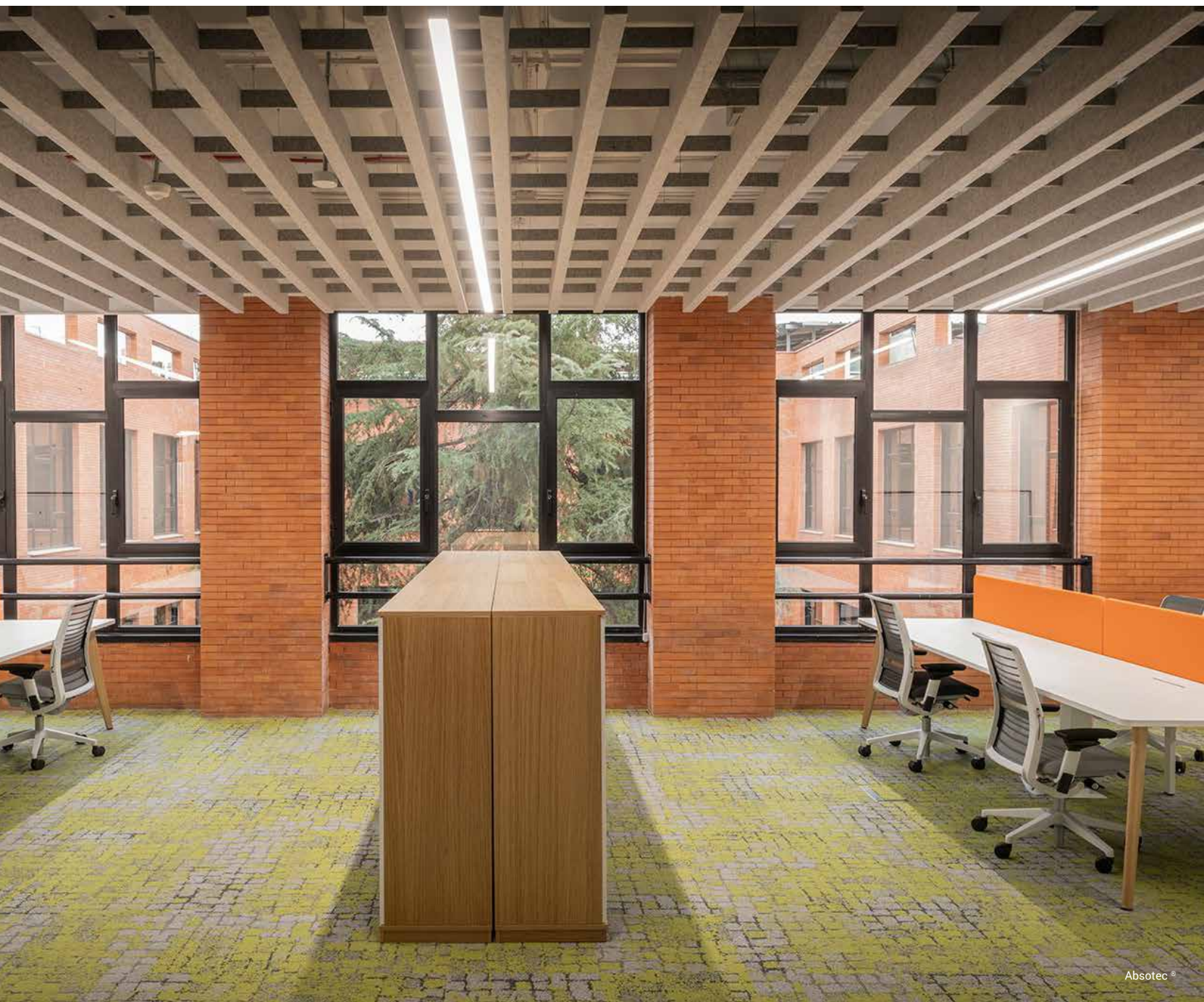





SKYLINE system

Sistema SKYLINE

MODULE / MÓDULO 900 x 2360 x 105 mm
 SURFACE / SUPERFICIE 2,124 m²

Customised sizes available upon request _ *Consultar medidas personalizadas.*

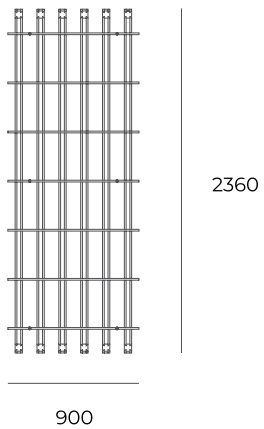

HARMONIUM SKYLINE U 75/50 D 100

SKU# DBHA0037

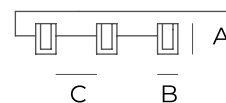
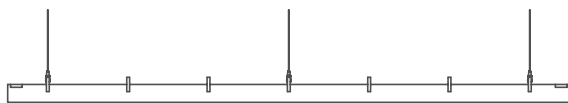
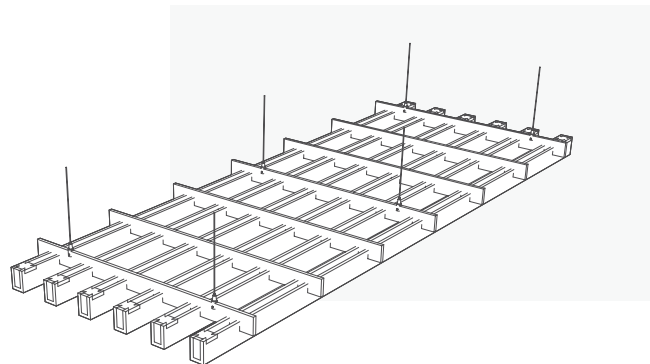

A: 75 mm
 B: 50 mm
 C: 100 mm

MODULARITY / MODULACIÓN

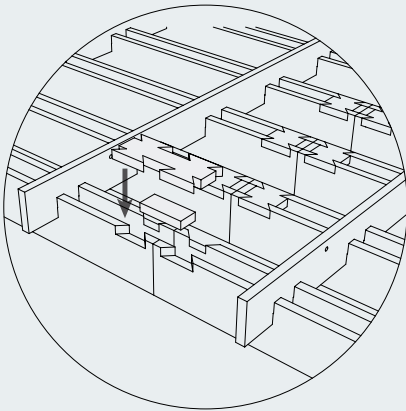

To preserve the modularity of the elements, the boxes are joined together using a special connecting piece, as well as a rectangular element that ensures continuity. This allows large ceiling spaces to be covered in a regular and harmonious way.

Para mantener la modularidad de los elementos, la unión entre cajas se hará mediante una pieza especial que las une, además de un elemento rectangular que asegura su continuidad. De esta forma se consigue cubrir grandes espacios de techo de forma regular y armoniosa.

ASSEMBLY / MONTAJE

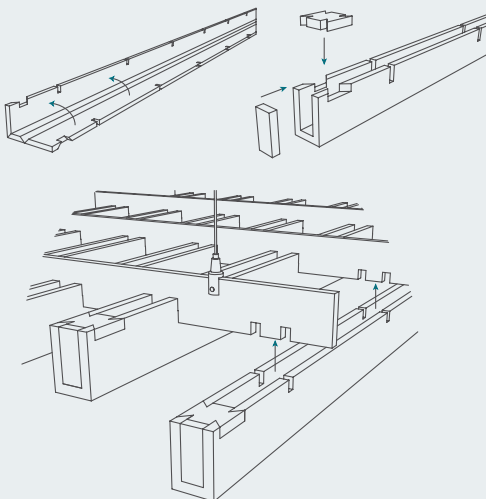

The boxes are pressure-fitted to the suspension elements without the need for special tools, facilitating installation and reducing assembly time.

Las vigas se unen mediante presión a los elementos de suspensión sin necesidad de herramientas especiales, facilitando la instalación y reduciendo el tiempo de montaje.

Suspended waves that transform sound into harmony.

Ondas suspendidas que transforman el sonido en armonía.

ONA system *Sistema ONA*

The **ONA system** redefines acoustic comfort with a fluid, organic design that evokes movement. Their wavy shapes absorb noise and provide an immersive and light aesthetic. Made from recyclable PET, it combines sustainability with high sound-absorbing performance. They are easy to install on ceilings, adapting elegantly to any space. An architectural solution that combines design, innovation and acoustic well-being.

*El **sistema ONA** redefine el confort acústico con un diseño fluido y orgánico que evoca movimiento. Sus formas ondulantes absorben el ruido y aportan una estética envolvente y ligera. Fabricado en PET reciclable, combina sostenibilidad y altas prestaciones fonoabsorbentes. Se instala fácilmente en techos, adaptándose a cualquier espacio con elegancia. Una solución arquitectónica que une diseño, innovación y bienestar sonoro.*









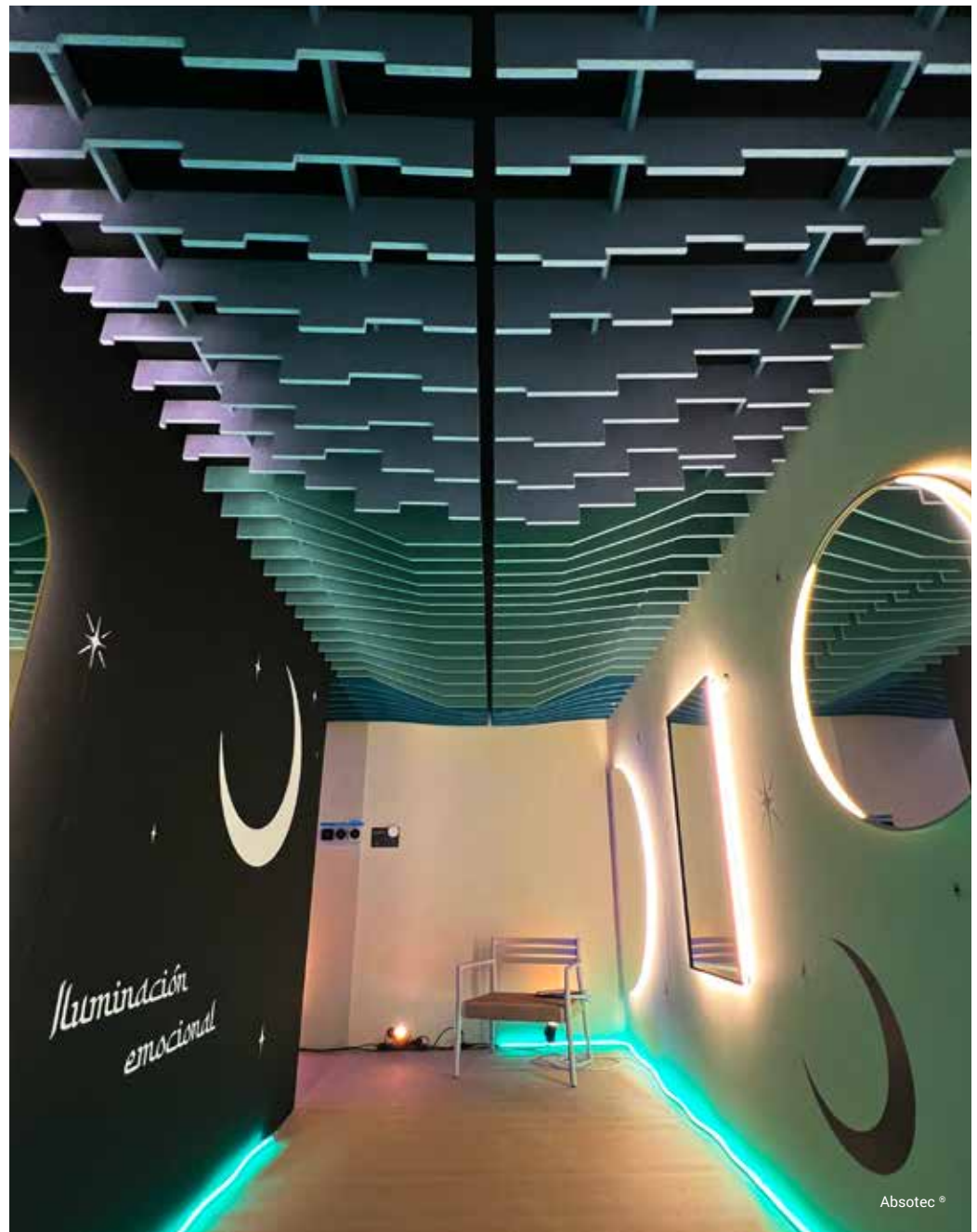





ONA system *Sistema ONA*

MODULE / *MÓDULO* 2400 x 2400 mm
SURFACE / *SUPERFICIE* 5,76 m²

Custom sizes available upon request _ *Consultar medidas personalizadas.*

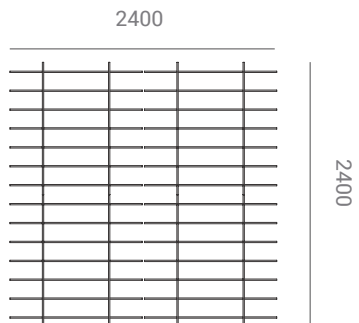

CURVE

SKU# DBHA0036

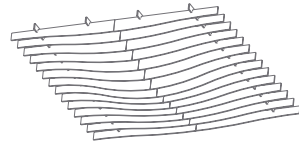

MODULE *MÓDULO* / 2400 x 2400 x 320 mm (5,76 m²)

Maximum slat height *Altura máx. lama* / 290 mm

Minimum slat height *Altura mín. lama* / 90 mm

NIMBUS

SKU# DBHA0192

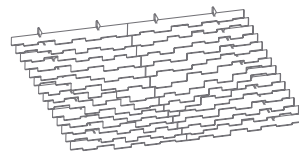

MODULE *MÓDULO* / 2400 x 2400 x 332 mm (5,76m²)

Maximum slat height *Altura máx. lama* / 305 mm

Minimum slat height *Altura mín. lama* / 90 mm

DIAGONAL

SKU# DBHA0193

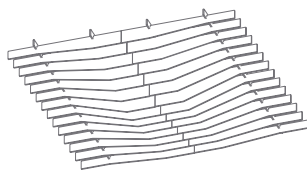

MODULE *MÓDULO* / 2400 x 2400 x 197 mm (5,76 m²)

Maximum slat height *Altura máx. lama* / 290 mm

Minimum slat height *Altura mín. lama* / 90 mm

JAGGY

SKU# DBHA0194

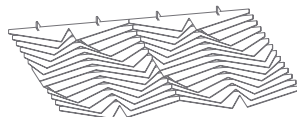

MODULE *MÓDULO* / 2400 x 2400 x 197 mm (5,76 m²)

Maximum slat height *Altura máx. lama* / 170 mm

Minimum slat height *Altura mín. lama* / 40 mm

REVERBSHIELD
SKU# DBHA0105

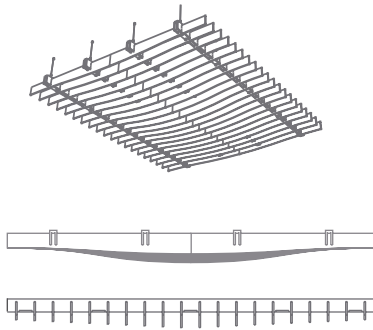

Design *_Diseño:* JC de la Morena.

MODULE *MÓDULO* / 2400 x 2780 x 200 mm (6,67 m²)

Maximum slat height *Altura máx. lama* / 200 mm
Minimum slat height *Altura mín. lama* / 120 mm

DUNES
SKU# DBHA0165

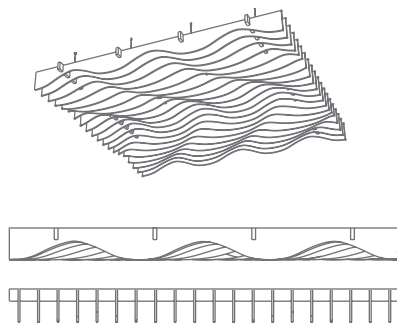

Design *_Diseño:* JC de la Morena.

MODULE *MÓDULO* / 2500 x 2500 x 200 mm (6,25 m²)

Maximum slat height *Altura máx. lama* / 200 mm
Minimum slat height *Altura mín. lama* / 82 mm

RESONANCE
SKU# DBHA0031

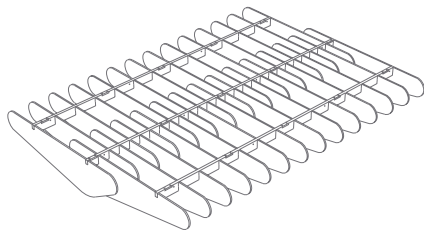

Design *_Diseño:* MOJA Design.

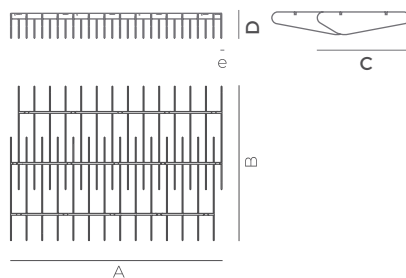

MODULE *MÓDULO* (A x B) / 2780 x 2035 (5,64 m²)

Slat width *Ancho lama* (C) / 1360 mm
Total height *Altura total* (D) / 336 mm



RHOMBUS

SKU# DBHA0234

Design *_Diseño:* JC de la Morena.

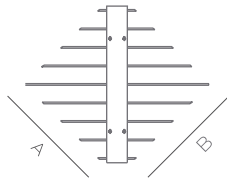
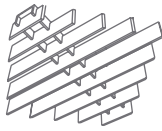
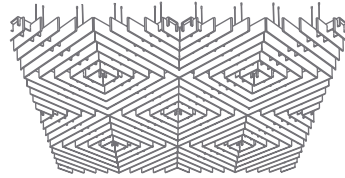

MODULE *MÓDULO* / 950 x 950 mm (0,9 m²)

D 170 mm

PACK / 2 UND / TOTAL 1900 x 950 mm (1,8 m²)

ASSEMBLY / MONTAJE

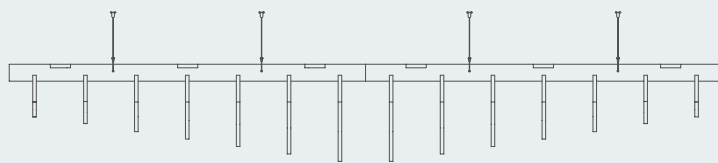
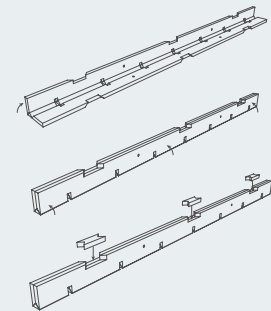
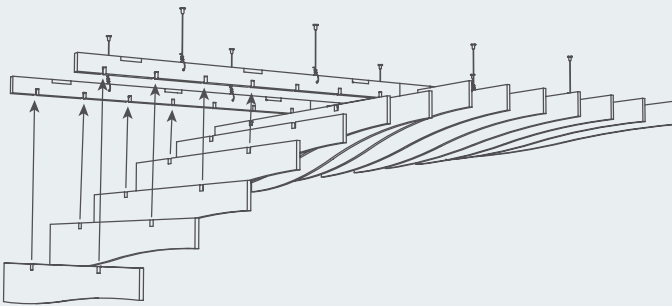

1 2 3 4 5 6 7 7 6 5 4 3 2 1

The baffles are pressure-fitted to the double-thickness suspension elements without the need for special tools, facilitating installation and reducing assembly time.

Los baffles se unen mediante presión a los elementos de suspensión de doble espesor sin necesidad de herramientas especiales, facilitando la instalación y reduciendo el tiempo de montaje.

Precise order that
sculpts sonic purity.

*Orden preciso que
esculpe la pureza sonora.*

Baffles systems *Sistemas de baffles*

The **baffles systems** offer a clean and orderly aesthetic, with equidistant slats that generate an elegant and precise acoustic landscape. Their modular structure facilitate large and homogeneous compositions with great visual impact. Made from recyclable PET, they guarantee a perfect balance between performance and sustainability. Ideal for creating quiet, functional and architecturally pure environments.

Los **sistemas de baffles** ofrecen una estética limpia y ordenada, con lamas equidistantes que generan un paisaje acústico elegante y preciso. Su estructura modular facilita composiciones amplias, homogéneas y de gran impacto visual. Fabricados en PET reciclable, garantiza un equilibrio perfecto entre rendimiento y sostenibilidad. Ideal para crear ambientes silenciosos, funcionales y arquitectónicamente puros.





Absotec®

LONG 15CM

SKU# DBHA0195

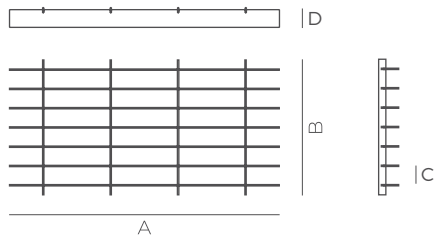

A x B / 2400 x 1200 mm (2,88 m²)

C / 170 mm

D / 177 mm

BALANCE

SKU# DBHA0114

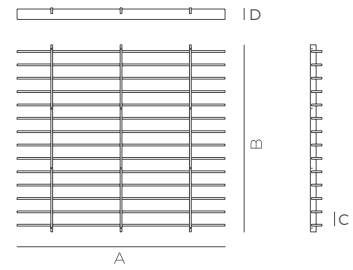

Design *_Diseño:* JC de la Morena.

A x B / 2500 x 2780 mm (6,95 m²)

C / 155 mm

D / 139 mm

LONG 21CM

SKU# DBHA0196

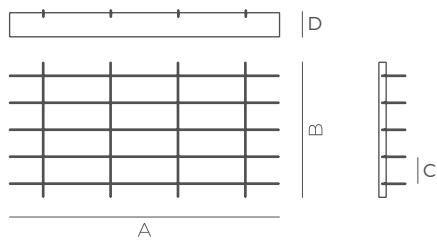

A x B / 2400 x 1200 mm (2,88 m²)

C / 240 mm

D / 214 mm

WAVES

SKU# DBHA0050

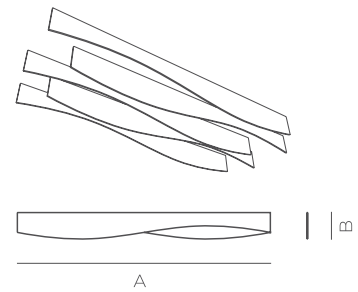

A / 2780 mm

B / min. 155 mm max. 290 mm

Pack 5 uds

BASIC MODULE

SKU# DBHA0072

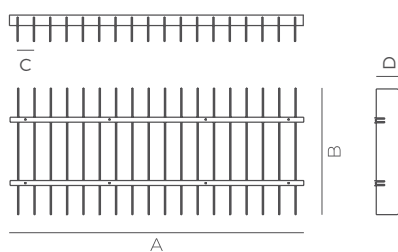

Design *_Diseño:* JC de la Morena.

A x B / 2780 x 1200 mm (2,34 m²)

C / 142 mm

D / 230 mm

Delicate geometries
that renew silence.

*Geometrías sutiles que
renuevan el silencio.*

Drop ceilings *Techos registrables*

The **drop ceilings** combine technical accessibility and contemporary design, renewing traditional surfaces with unique geometries. Their sound-absorbing panels reduce reverberation and bring rhythm and personality to the space. Made from recyclable PET, they complement projects that seek a balance between aesthetics and sustainability. A versatile alternative for improving acoustic comfort without complex interventions.

Los **techos registrables** combinan accesibilidad técnica y diseño contemporáneo, renovando las superficies tradicionales con geometrías únicas. Sus paneles fonoabsorbentes reducen la reverberación y aportan ritmo y personalidad al espacio. Fabricados en PET reciclable, acompañan proyectos que buscan equilibrio entre estética y sostenibilidad. Una alternativa versátil para mejorar el confort sonoro sin intervenciones complejas.







Drop ceilings *Techos registrables*

DIMENSIONS / *DIMENSIONES*

A / 595 mm

B / 595 mm

e / 12 mm

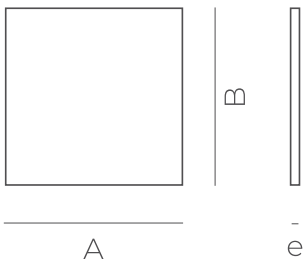

BASIC

SKU# DBHA0197

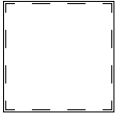

The drop ceiling panels are supplied in packs of 8 units, with designs that can be combined to create multiple acoustic decoration options for the ceiling.

Los paneles de techo registrable se suministran en packs de 8 uds, con diseños que se pueden combinar para crear múltiples opciones de decoración acústica en el techo.

GRID

SKU# DBHA0198

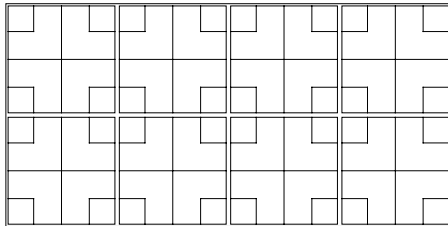
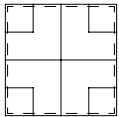

DIAMOND

SKU# DBHA0200

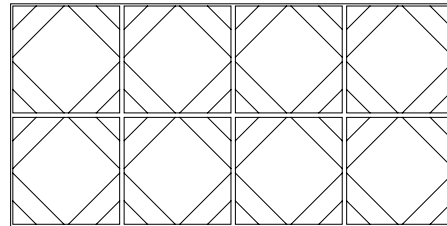
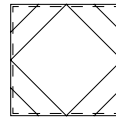

DIAGONAL

SKU# DBHA0199

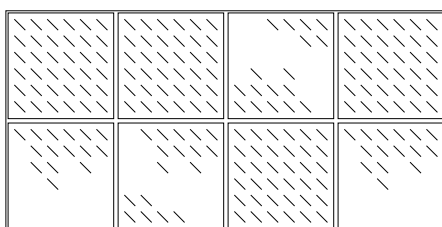
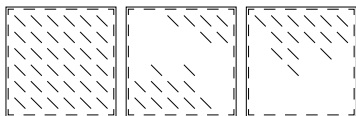

DIVERT

SKU# DBHA0201

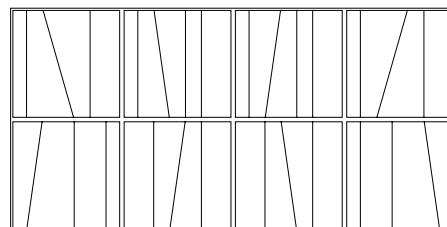
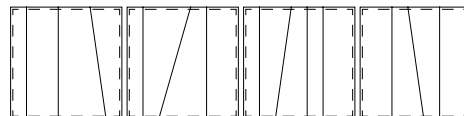

TRIANGLES

SKU# DBHA0202

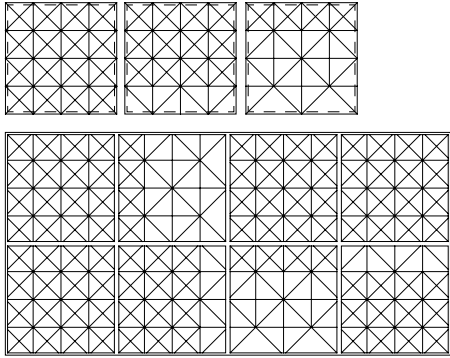

SPIKE

SKU# DBHA0205

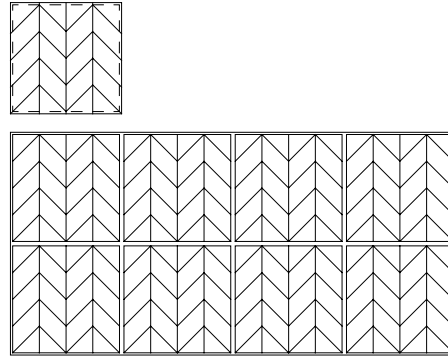

GEOMETRIC

SKU# DBHA0203

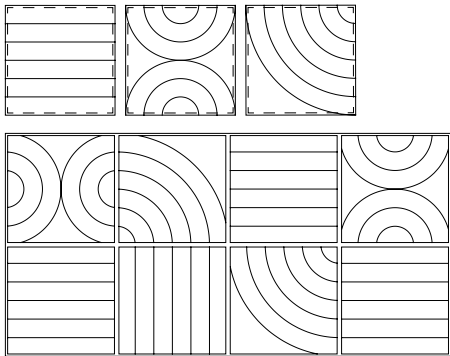

INTERSECTIONS

SKU# DBHA0206

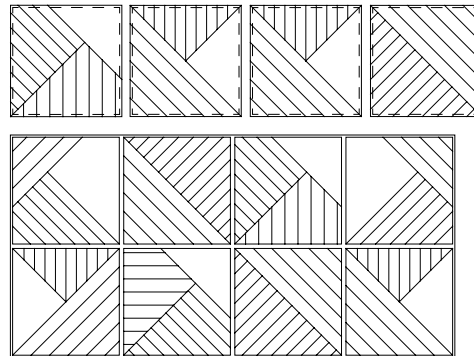

ARCH

SKU# DBHA0204

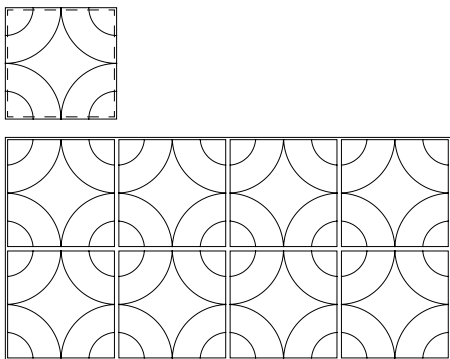

CIRCLES

SKU# DBHA0207

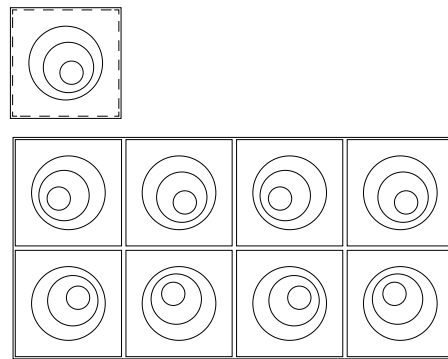

DESIGN / DISEÑO



V-cut
Biselado

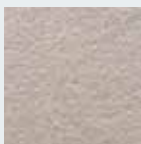

Flawless
Plano



Thru-cut
Agujero pasante

ASSEMBLY / MONTAJE

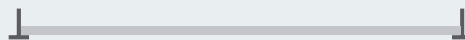

Direct installation on a standard 600 x 600 mm profile structure for drop ceiling panels.

Colocación directa sobre una estructura de perfiles estándar de 600 x 600 mm para placas de techo registrable.

Suspended pieces that
caress the acoustics.

*Piezas suspendidas que
acarician la acústica.*

Acoustic islands *Islas acústicas*

Acoustic islands bring lightness, movement and visual depth, suspended above the space like sculptural pieces. Their sound-absorbing capacity improves acoustic comfort while respecting the original architecture. Made from recyclable PET, they combine sustainability and aesthetics in a single gesture. A decorative, flexible and elegant solution that brings serenity from above.

Las **islas acústicas** aportan ligereza, movimiento y profundidad visual, suspendidas sobre el espacio como piezas escultóricas. Su capacidad fonoabsorbente mejora el confort acústico respetando la arquitectura original. Fabricadas en PET reciclable, suman sostenibilidad y estética en un único gesto. Una solución decorativa, flexible y elegante que aporta serenidad desde el aire.











CIRCLE

SKU# DBHA0208

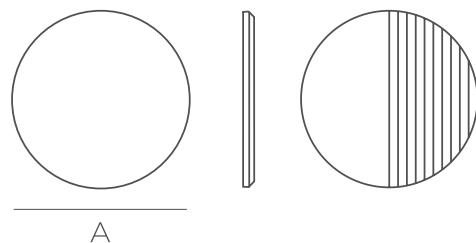

A: 600 / 1200 mm

PACKS

CR.1: 8 uds Ø600 mm

CR.2: 2 uds Ø1200 mm

LEAF

SKU# DBHA0209

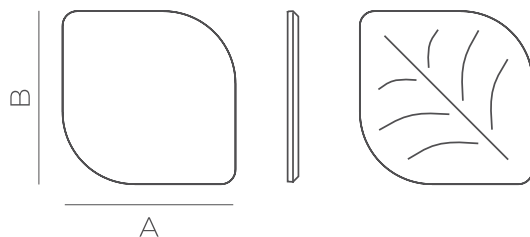
A: 600 / 1200 mm
B: 600 / 800 / 1200 mm**PACKS**

LF.1: 8 uds 600 x 600 mm

LF.2: 6 uds 600 x 800 mm

LF.3: 2 uds 1200 x 1200 mm

PETAL

SKU# DBHA0034 - 35

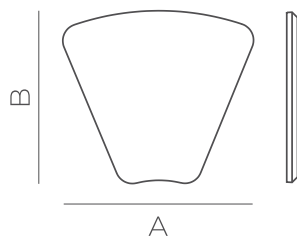

A x B: 616 x 557 / 930 x 840 mm

PACKS

PT.1: 8 uds 610 x 560 mm

PT.2: 3 uds 930 x 840 mm

FLAKE

SKU# DBHA0210

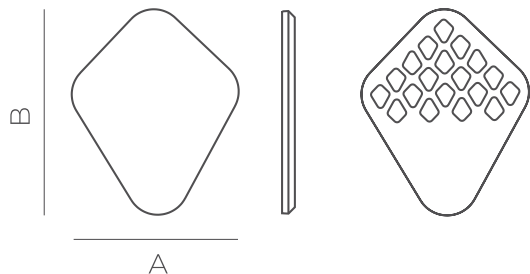

A x B: 650 x 800 mm

PACK

LF.1: 6 uds 650 x 800 mm

ECLIPSE

SKU# DBHA0211

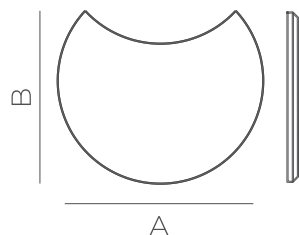

A x B: 700 x 588 / 1080 x 908 mm

PACKS

EC.1: 8 uds 700 x 588 mm

EC.2: 3 uds 1080 x 908 mm

MOON

SKU# DBHA0039 - 40

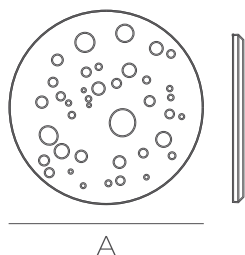

Design *_Diseño:* Clara Sullà.

A: 1205 / 945 mm

PACKS

L: 2 uds Ø1205 mm

S: 3 uds Ø945 mm

BRICK

SKU# DBHA0212

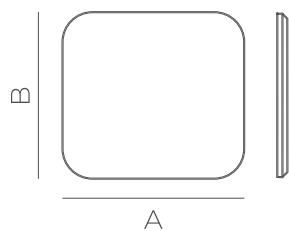

A: 600 / 800 / 1200 / 1600 / 2000 mm

B: 600 / 800 / 1200 mm

PACKS:

BR.1: 8 uds 600 x 600 mm

BR.2: 6 uds 600 x 800 mm

BR.3: 4 uds 600 x 1200 mm

BR.4: 3 uds 800 x 800 mm

BR.5: 3 uds 800 x 1200 mm

BR.6: 2 uds 1200 x 1200 mm

MONTSERA

SKU# DBHA0032 - 33

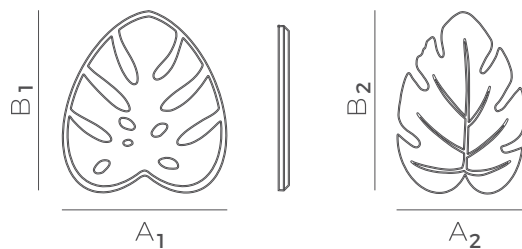

Design *_Diseño:* Clara Sullà.

A₁ x B₁: 1281 x 1158 / 1055 x 953 mm

A₂ x B₂: 1505 x 1057 / 1172 x 822 mm

PACKS

L: 1 ud 1281 x 1158 mm + 1 ud 1505 x 1057 mm

S: 2 uds 1055 x 953 mm + 1 ud 1172 x 822 mm

STONES

SKU# DBHA0213

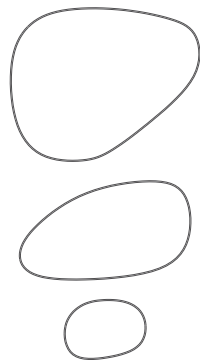
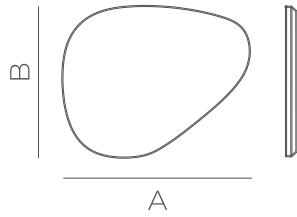

A x B: 1450 x 1090 / 1290 x 675 / 600 x 425 mm

PACK1 ud 1450 x 1090 mm + 1 ud 1290 x 675 mm
+ 1 ud 600 x 425 mm**PEBBLE**

SKU# DBHA0038

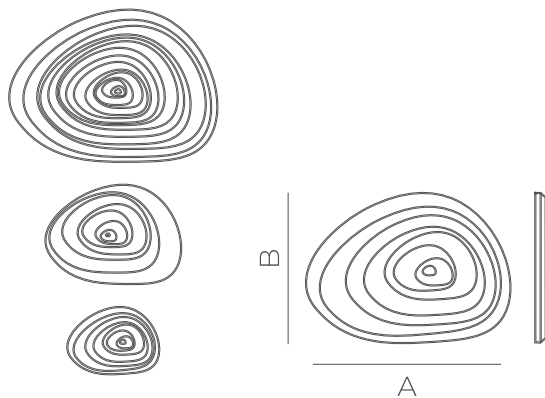
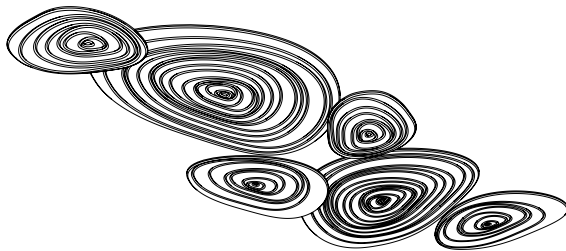
Design *_Diseño:* Clara Sullà.

A x B: 1200 x 877 / 787 x 574 / 532 x 389 mm

PACK2 uds 1200 x 877 + 2 uds 787 x 574
+ 2 uds 532 x 389 mm

OAK

SKU# DBHA0161 - 62

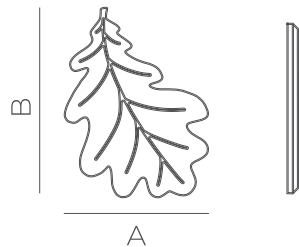

Design *_Diseño:* Clara Sullà.

A x B: 1670 x 1138 / 1100 x 750 mm

PACKS

L: 2 uds 1670 x 1138 mm

S: 4 uds 1100 x 750 mm

ROSE

SKU# DBHA0160

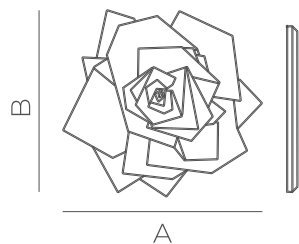

Design *_Diseño:* Clara Sullà.

A x B: 1150 x 1140 mm

PACKS

2 uds 1150 x 1140 mm

HEXAGONAL BOX

SKU# DBHA0136

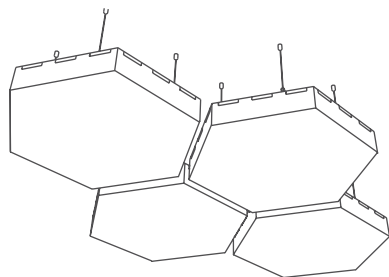

Design *_Diseño:* JC de la Morena.

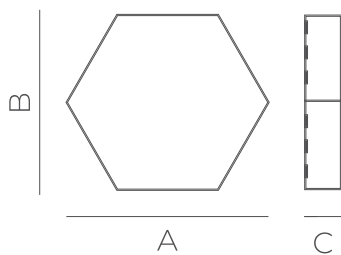

A x B x C: 600 x 520 x 80 mm

PACK

4 uds 600 x 520 x 80 mm

WALL PANELS

REVESTIMIENTOS

Surfaces that transform
sound into art.

*Superficies que transforman
el sonido en arte.*



Living surfaces that
breathe sound harmony.

*Superficies vivas que
respiran armonía sonora.*

Wall coverings *Revestimientos*

Wall coverings transform walls into living surfaces where sound is softened and aesthetics are intensified. With high-precision machined designs, they add texture, depth and character to any environment. Recyclable PET ensures sustainability and high acoustic performance. Perfect for projects seeking a balance between contemporary design and sound functionality.

*Los **revestimientos** acústicos transforman paredes en superficies vivas donde el sonido se suaviza y la estética se intensifica. Con diseños mecanizados de gran precisión, aportan textura, profundidad y carácter a cualquier ambiente. El PET reciclable asegura sostenibilidad y un alto rendimiento acústico. Perfecto para proyectos que buscan equilibrio entre diseño contemporáneo y funcionalidad sonora.*



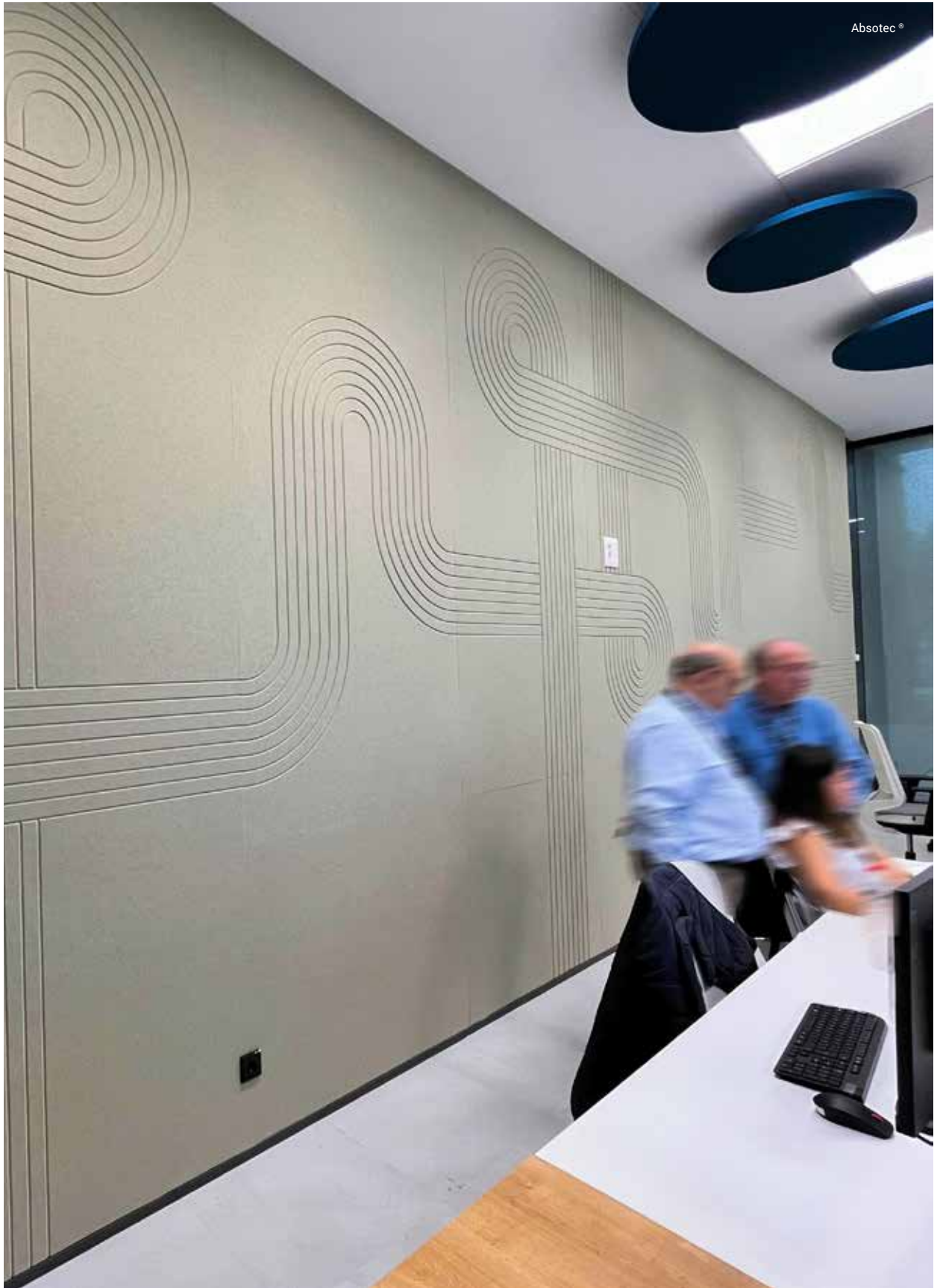



Absotec®







DROPS

SKU# DBHA0214

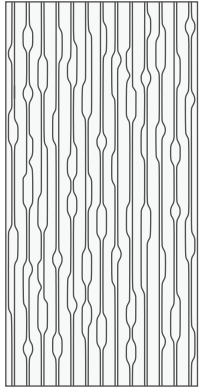

1200 x 2400 mm
1200 x 2780 mm

PULSE

SKU# DBHA0215

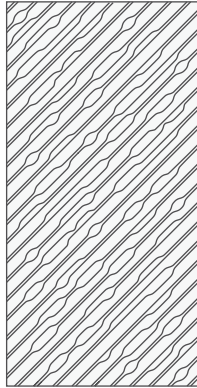

1200 x 2400 mm
1200 x 2780 mm

ROOTS

SKU# DBHA0010

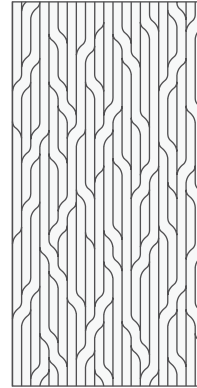

1200 x 2400 mm
1200 x 2780 mm

LAUREL

SKU# DBHA0008

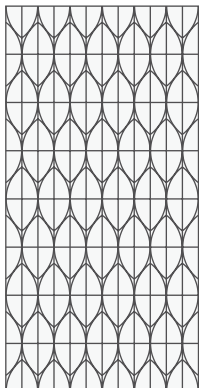

1200 x 2711 mm

SPIKE

SKU# DBHA0216

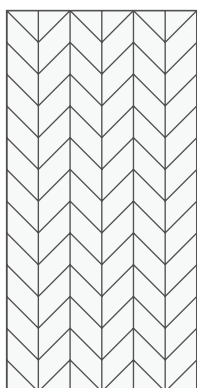

1200 x 2400 mm

LINEAL 1

SKU# DBHA0217

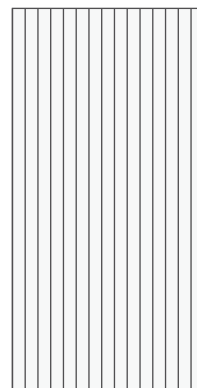

1200 x 2400 mm
1200 x 2780 mm

LINEAL 2

SKU# DBHA0218

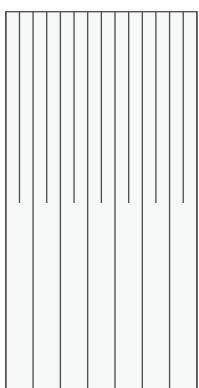

1200 x 2400 mm
1200 x 2780 mm

LINEAL 3

SKU# DBHA0219

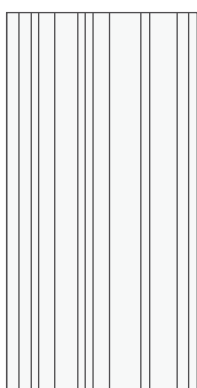

1200 x 2400 mm
1200 x 2780 mm

WAVES

SKU# DBHA0220

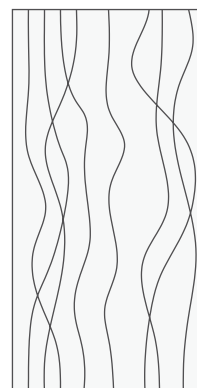

1200 x 2400 mm
1200 x 2780 mm

CUBE 1

SKU# DBHA0000

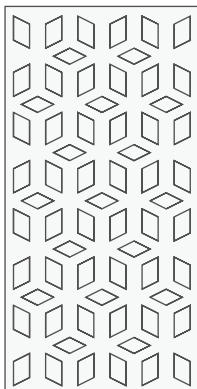

1200 x 2780 mm

CUBE 2

SKU# DBHA0221

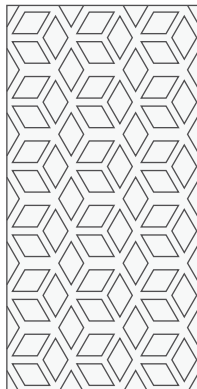

1200 x 2400 mm

HILLS

SKU# DBHA0007

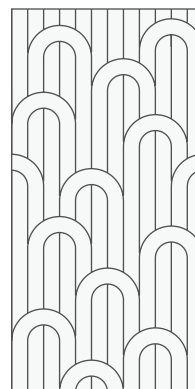

1200 x 2780 mm

INTERSECTIONS 1

SKU# DBHA0222

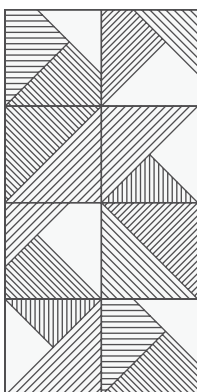

1200 x 2400 mm

INTERSECTIONS 2

SKU# DBHA0223

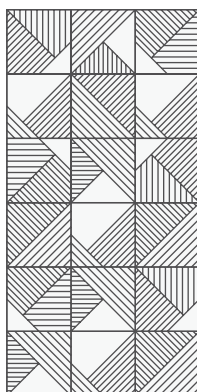

1200 x 2400 mm

HARMONY

SKU# DBHA0025

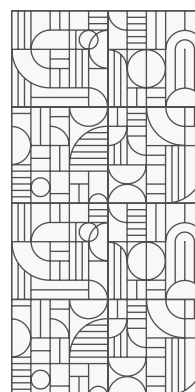

1200 x 2400 mm

DISRUPTIVE

SKU# DBHA0014

Design *_Diseño*
Nerea Orenes.

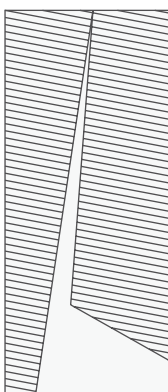

1200 x 2780 mm

FLOW

SKU# DBHA0005

Design *_Diseño*
Nerea Orenes.

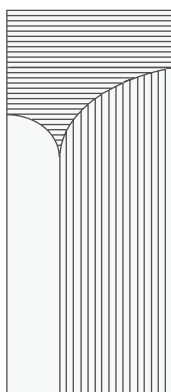

1200 x 2780 mm

SINGULARCH

SKU# DBHA0006

Design *_Diseño*
Nerea Orenes.

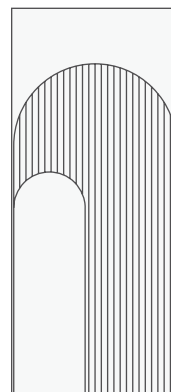

1200 x 2780 mm

EXZENTRIC

SKU# DBHA0017

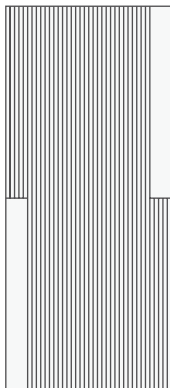
Design *_Diseño*
Nerea Orenes.

1200 x 2780 mm

PLINTH

SKU# DBHA0018

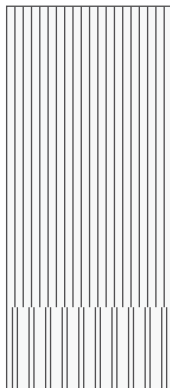
Design *_Diseño*
Nerea Orenes.

1200 x 2780 mm

TABLEAU

SKU# DBHA0235

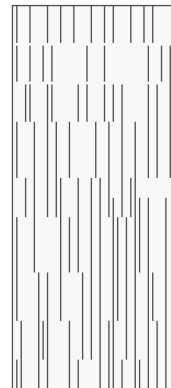
Design *_Diseño*
Nerea Orenes.

1200 x 2780 mm

THE BAU LEGACY

SKU# DBHA0030

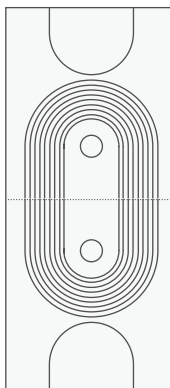
Design *_Diseño*
Elena Mas Parres.

1200 x 2780 mm

2-unit pack available
Disponibile pack 2 uds
1200 x 1390 mm.**FRAGMENTS**

SKU# DBHA0003

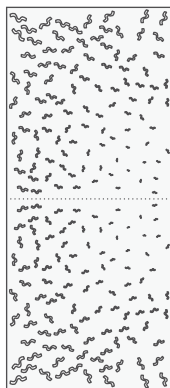
Design *_Diseño*
MOJA Design.

1200 x 2780 mm

2-unit pack available
Disponibile pack 2 uds
1200 x 1390 mm.**FREEDOM**

SKU# DBHA0002

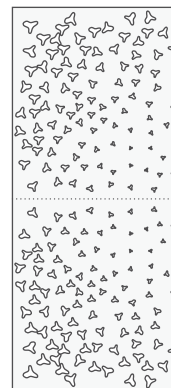
Design *_Diseño*
MOJA Design.

1200 x 2780 mm

2-unit pack available
Disponibile pack 2 uds
1200 x 1390 mm.**YIN YANG**

SKU# DBHA0179

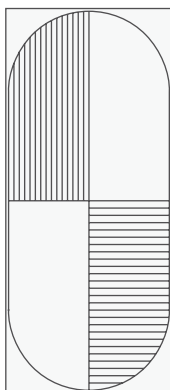
Design *_Diseño*
Nerea Orenes.

1200 x 2780 mm

SHADOW

SKU# DBHA0190

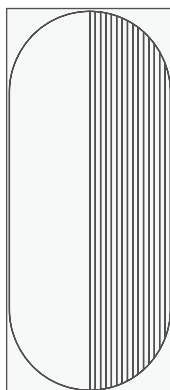
Design *_Diseño*
Nerea Orenes.

1200 x 2780 mm

CURL

SKU# DBHA0004

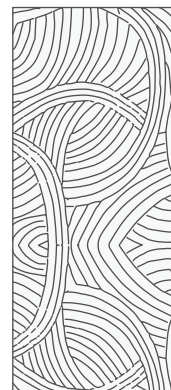
Design *_Diseño*
Clara Sullà.

1200 x 2780 mm

MOON PHASES
SKU# DBHA0013

Design *_Diseño*
Clara Sullà.

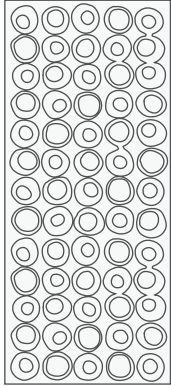

1200 x 2780 mm

MAZE
SKU# DBHA0012

Design *_Diseño*
MOJA Design.

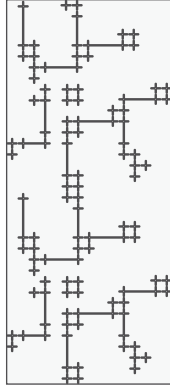

1200 x 2780 mm

GEOMETRIC
SKU# DBHA0001

Design *_Diseño*
MOJA Design.

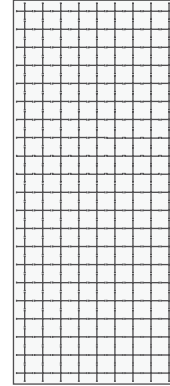

3600 x 2780 mm

INCISION
SKU# DBHA0236

Design *_Diseño*
MOJA Design.

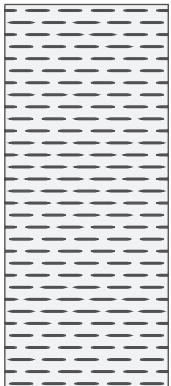

1200 x 2780 mm

TERRAIN
SKU# DBHA0129

Design *_Diseño*
JC de la Morena.

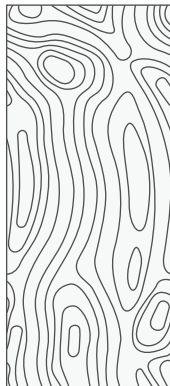

1200 x 2780 mm

OCEAN
SKU# DBHA0115

Design *_Diseño*
JC de la Morena.

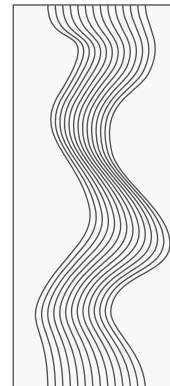

1200 x 2780 mm

LEAF CORNER
SKU# DBHA0009

Design *_Diseño*
MOJA Design.

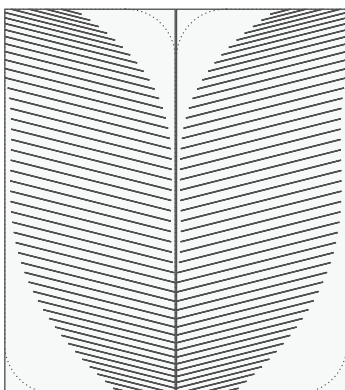

2400 x 2780 mm

Available with
rounded corners
Leaf Rounded
Disponibile
esquinas redondeadas
Leaf Rounded

TRIBECA
SKU# DBHA0016

Design *_Diseño*
Nerea Orenes.

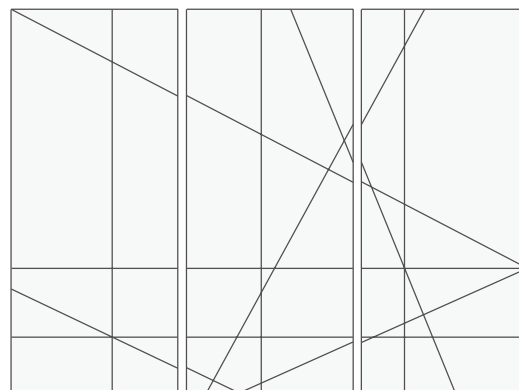

3600 x 2780 mm

LINES IN MOTION

SKU# DBHA0029

Design *_Diseño*
Elena Mas Parres.

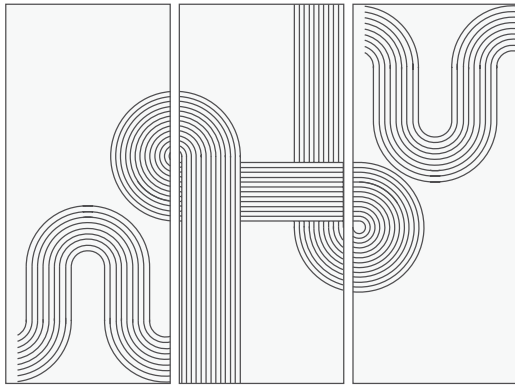

3600 x 2780 mm

ANTHROPOCENE

SKU# DBHA0024

Design *_Diseño*
Elena Mas Parres.

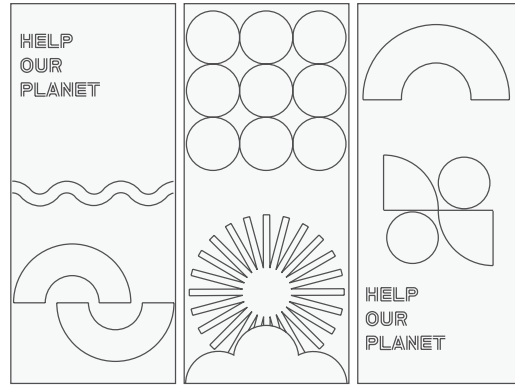

3600 x 2780 mm

SUN

SKU# DBHA0020

Design *_Diseño*
Elena Mas Parres.

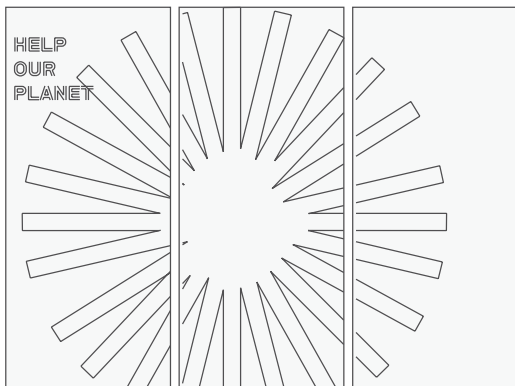

3600 x 2780 mm

SUNRISE

SKU# DBHA0019

Design *_Diseño*
Elena Mas Parres.

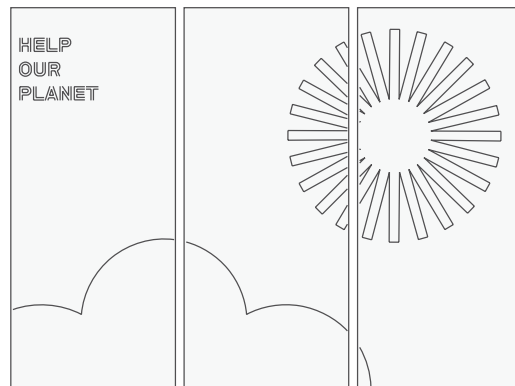

3600 x 2780 mm

EQUATOR

SKU# DBHA0021

Design *_Diseño*
Elena Mas Parres.

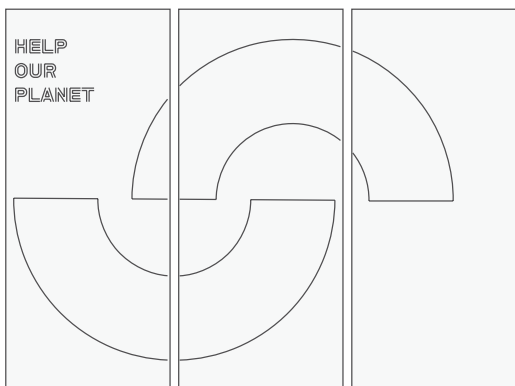

3600 x 2780 mm

JET LAG

SKU# DBHA0022

Design *_Diseño*
Elena Mas Parres.

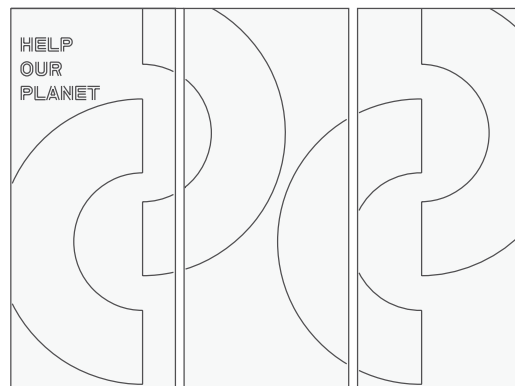

3600 x 2780 mm

RAW

SKU# DBHA0049



1220 x 2800 mm

FLAWLESS

SKU# DBHA0048

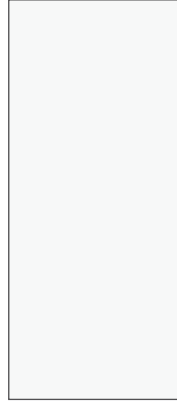

1200 x 2780 mm



EQUIPMENT

EQUIPAMIENTO

Functionality that can
be heard in silence.

*Funcionalidad que se
escucha en silencio.*



Lightweight dividers that envelop sound in calm.

Límites ligeros que envuelven el sonido en calma.

Desk dividers *Separadores de escritorio*

Desk dividers lightly separate spaces, providing visual privacy and acoustic comfort without compromising transparency. Their recyclable PET composition reduces noise and creates more peaceful and functional environments. Their customisable design allows them to be integrated into any architectural style. A versatile tool for defining spaces with elegance and acoustic sensitivity.

Los **separadores de escritorio** delimitan espacios con ligereza, aportando privacidad visual y confort sonoro sin perder transparencia. Su composición en PET reciclable reduce el ruido y crea ambientes más calmados y funcionales. Su diseño personalizable permite integrarlos en cualquier estilo arquitectónico. Una herramienta versátil para definir espacios con elegancia y sensibilidad acústica.





BASIC

SKU# DBHA0224

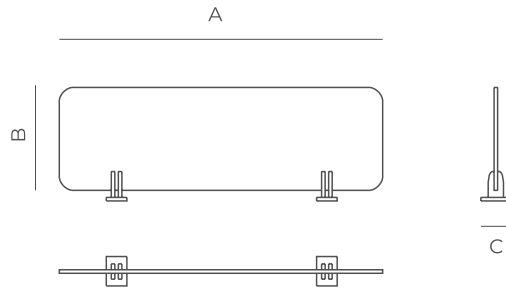

C: 100 mm

PACKS
9 / 6 / 4 uds

AxB custom dimensions available
Medidas personalizables AxB

VAULT

SKU# DBHA0046

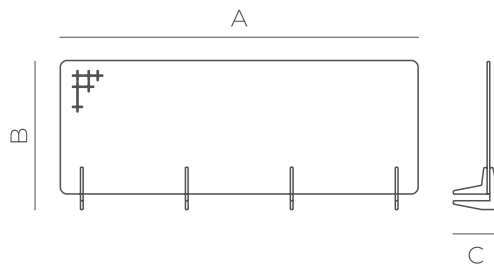

Design *_Diseño:* MOJA Design.

A: 1600 mm
B: 600 mm
C: 207 mm

AEGIS

SKU# DBHA0045

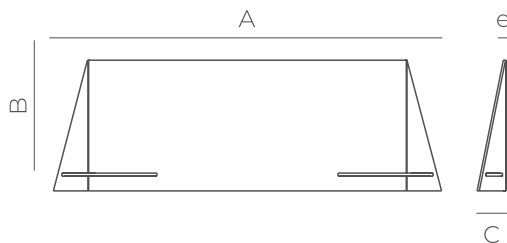

Design *_Diseño:* MOJA Design.

A: 1505 mm
B: 510 mm
C: 108 mm

CUSTOMIZATION PERSONALIZACIÓN

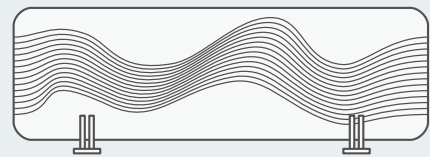
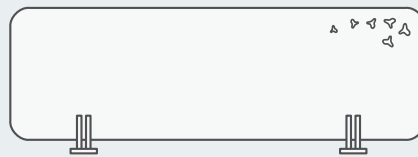
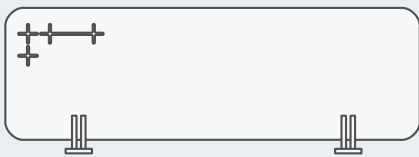

Customised desk divider.

Customise the design of the desk divider, choose from one of our suggestions, or create your own design, for example, with your company logo.

Separador personalizado.

Personaliza el diseño del separador, escoge entre alguno de los que te proponemos, o crea tu propio diseño, por ejemplo, con el logotipo de tu empresa.

Serene mobility that
shapes silence.

*Movilidad serena que
moldea el silencio.*

Room dividers *Separadores de ambientes*

Room dividers provide a versatile solution for managing sound in constantly changing environments. Their lightweight structure and recyclable PET panels allow them to be moved easily without compromising on high sound absorption performance. Available in smooth, printed or textured versions, they blend in as decorative pieces that enrich the space. An ideal solution for offices and activity areas where comfort must adapt to the rhythm of everyday life.

*Los **separadores de ambientes** aportan una respuesta versátil para gestionar el sonido en entornos que evolucionan constantemente. Su estructura ligera y los paneles de PET reciclable permiten moverlas con facilidad sin renunciar a un alto rendimiento fonoabsorbente. Disponibles en versiones lisas, impresas o con relieve, se integran como piezas decorativas que enriquecen el espacio. Una solución ideal para oficinas y zonas de actividad donde el confort debe adaptarse al ritmo del día a día.*



BERLIN

SKU# DBHA0044

Design *_Diseño:* MOJA Design.

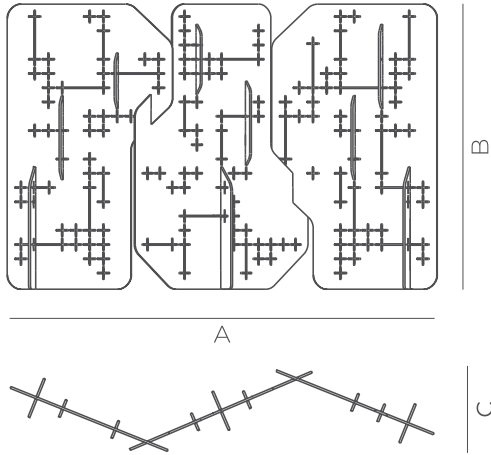

A x B x C (total): 2544 x 1685 x 483 mm

MORPH ROOM DIVIDER

SKU# DBHA0066

Design *_Diseño:* MOJA Design.

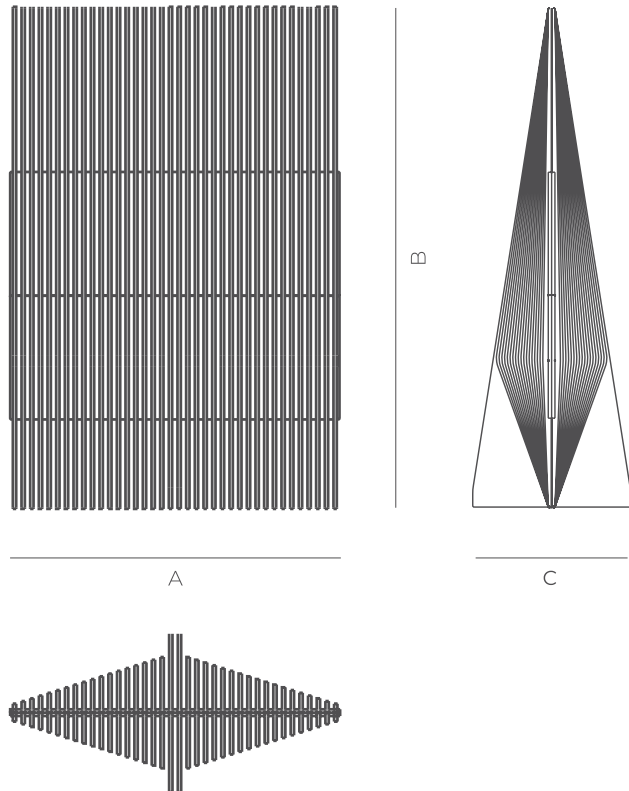

FOCUS OPEN 2024
 Baden-Württemberg
 International Design Award
Silver

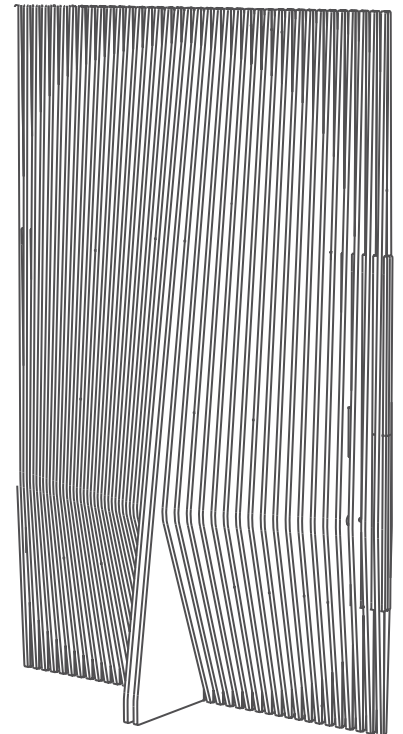

A x B x C (total): 1180 x 1800 x 570 mm

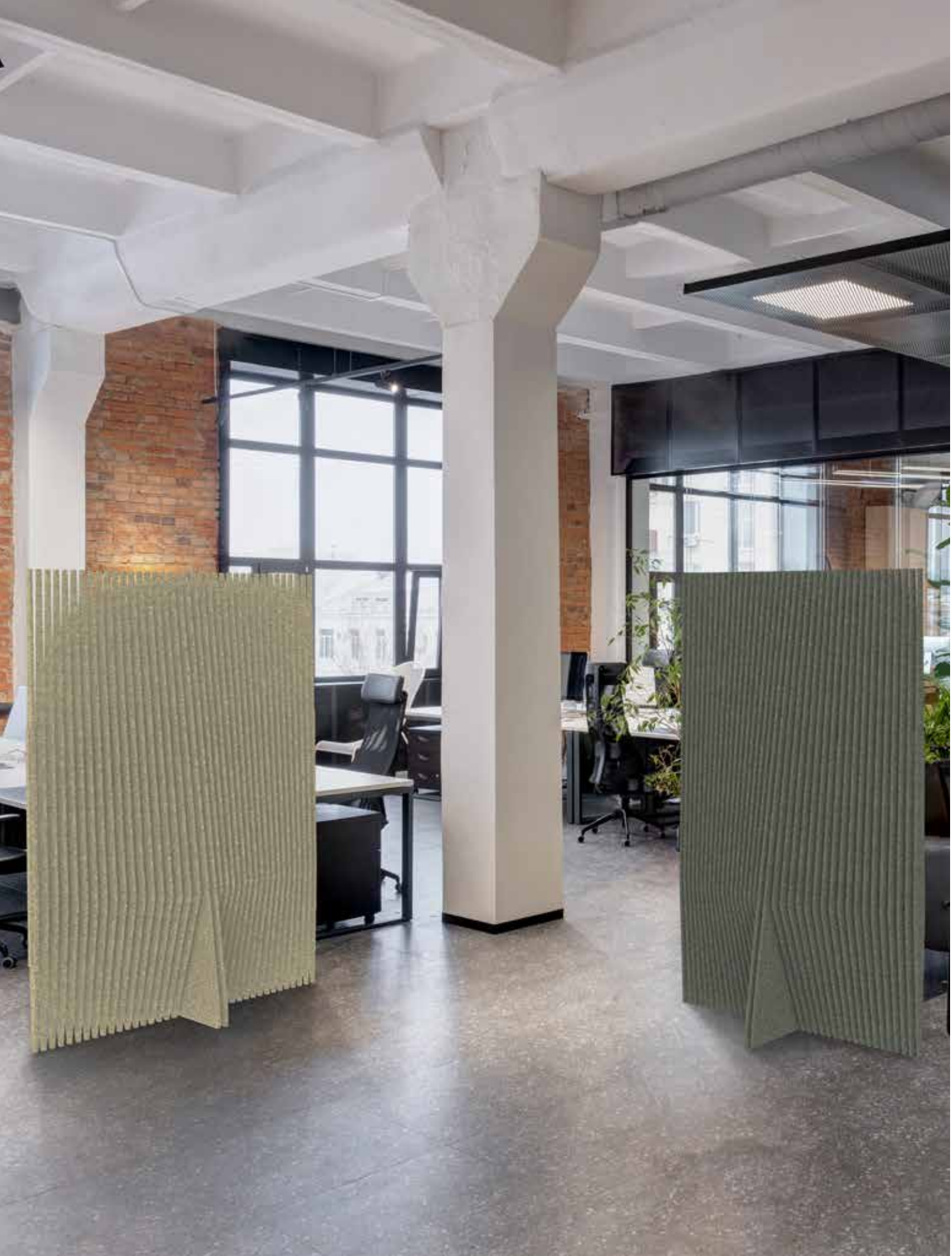

Vertical pieces that
draw silence into the air.

*Piezas verticales que
dibujan silencio en el aire.*

Acoustic screens *Celosías acústicas*

Acoustic screens function as suspended elements that combine design and sound absorption in a single vertical gesture. Their stylised shapes soften reverberation while adding rhythm, texture and a sculptural presence to the space. Made from recyclable PET, they are lightweight, sustainable and highly customisable in terms of geometry, colours and finishes. An elegant solution for creating dynamic compositions that beautify and acoustically balance any environment.

*Las **celosías acústicas** funcionan como elementos suspendidos que combinan diseño y absorción sonora en un solo gesto vertical. Sus formas estilizadas suavizan la reverberación mientras aportan ritmo, textura y una presencia escultórica al espacio. Fabricadas en PET reciclable, son ligeras, sostenibles y altamente personalizables en geometrías, colores y acabados. Una solución elegante para crear composiciones dinámicas que embellecen y equilibran acústicamente cualquier ambiente.*

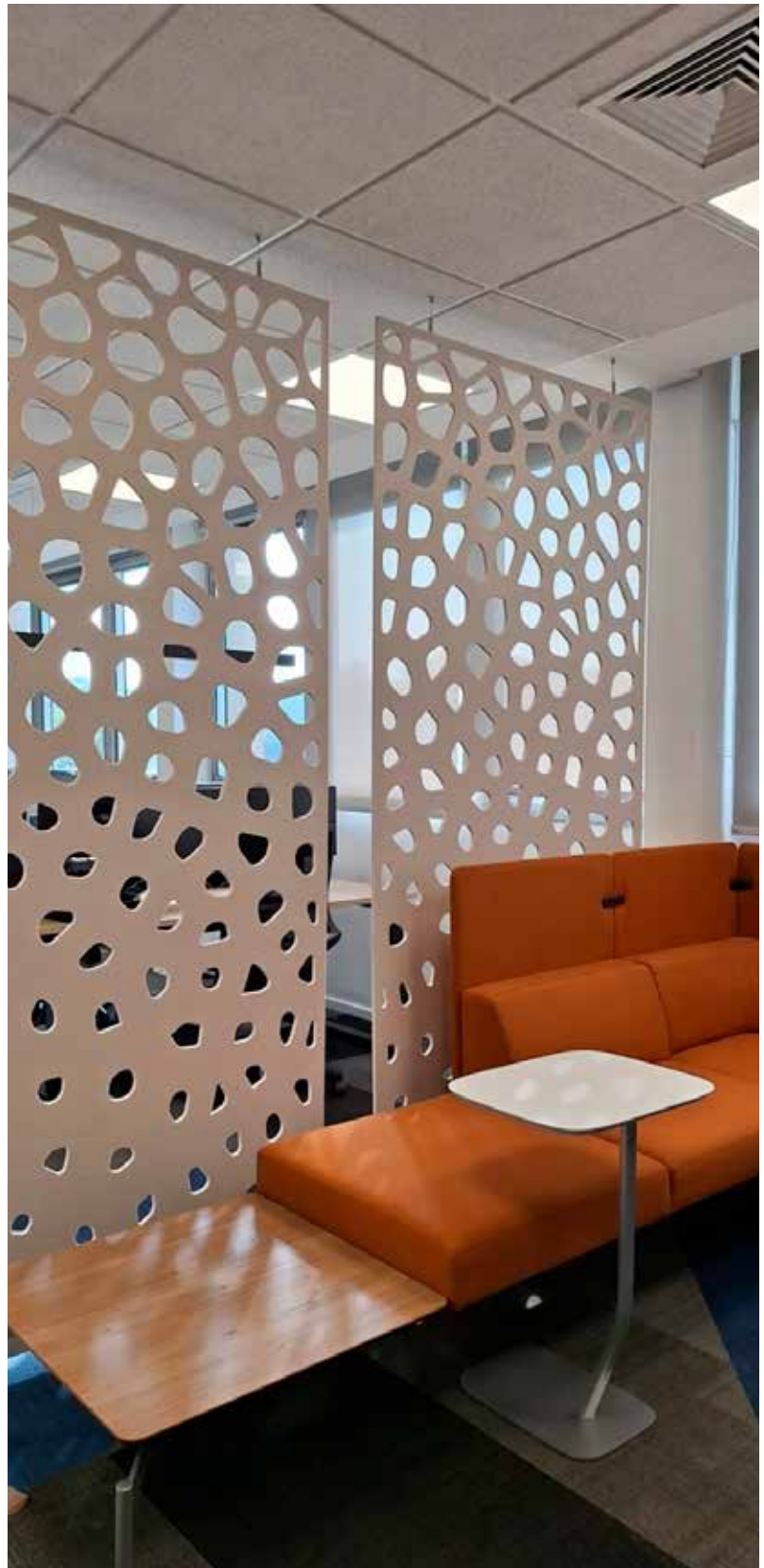

CIRCLE

SKU# DBHA0227

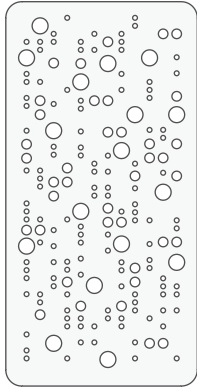

1200 x 2780 mm

BUBBLES

SKU# DBHA0228

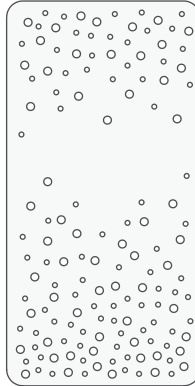

1200 x 2780 mm

CUBE

SKU# DBHA0229

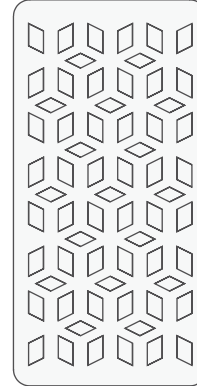

1200 x 2780 mm

PULSE

SKU# DBHA0230

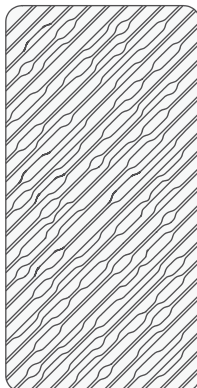

1200 x 2780 mm

ROOTS

SKU# DBHA0231

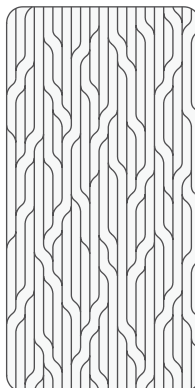

1200 x 2780 mm

STEEL

SKU# DBHA0011

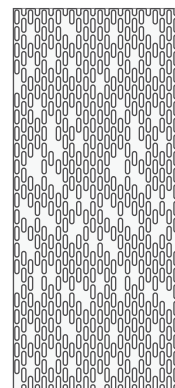

1200 x 2760 mm

VORONOI

SKU# DBHA0047

Design *_Diseño*
MOJA Design.

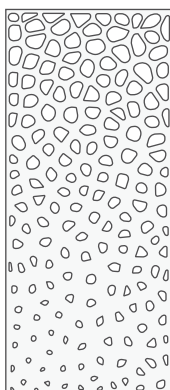

1200 x 2780 mm

SAILOR

SKU# DBHA0171

Design *_Diseño*
Nerea Orenes.

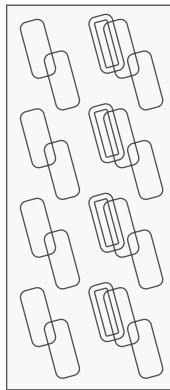

1200 x 2780 mm

FERN

SKU# DBHA0172

Design *_Diseño*
Clara Sullà.

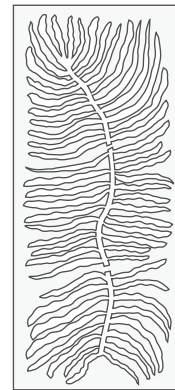

1200 x 2780 mm

AZTECA
SKU# DBHA0173

Design *_Diseño*
Elena Mas Parres.

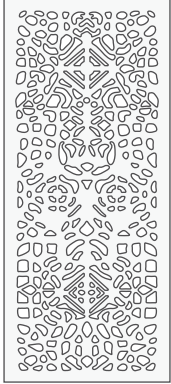

1200 x 2780 mm

AFRICA
SKU# DBHA0174

Design *_Diseño*
Elena Mas Parres.

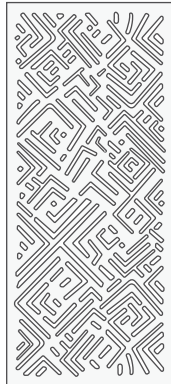

1200 x 2780 mm

JAPAN
SKU# DBHA0175

Design *_Diseño*
Elena Mas Parres.



1200 x 2780 mm

NEOLITIC
SKU# DBHA0176

Design *_Diseño*
Elena Mas Parres.

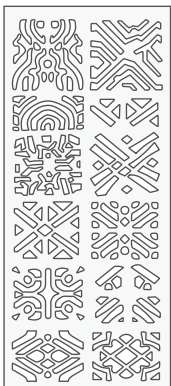

1200 x 2780 mm

FLUID HOLES
SKU# DBHA0177

Design *_Diseño*
Elena Mas Parres.

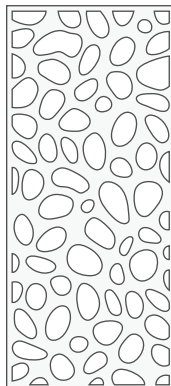

1200 x 2780 mm

LAVA
SKU# DBHA0178

Design *_Diseño*
Elena Mas Parres.

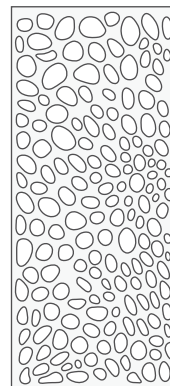

1200 x 2780 mm

FIGURATIF
SKU# DBHA0167



1200 x 2780 mm

Aerial sculptures that
shape silence.

*Esculturas aéreas que
dan forma al silencio.*

Ceiling creations *Creaciones para techo*

Ceiling creations are sculptural pieces that float above the space, transforming sound and elevating design to an artistic dimension. Made from recyclable PET, they combine bold shapes and sound-absorbing performance. These elements bring identity, character and personality to any environment. When acoustics become an architectural gesture.

Las **creaciones para techo** son piezas escultóricas que flotan sobre el espacio, transformando el sonido y elevando el diseño a una dimensión artística. Fabricadas en PET reciclable, combinan formas audaces y rendimiento fonoabsorbente. Son elementos que aportan identidad, carácter y personalidad a cualquier ambiente. Cuando la acústica se convierte en un gesto arquitectónico.





MORPH SOFT EDGE PENDANT

SKU# DBHA0117

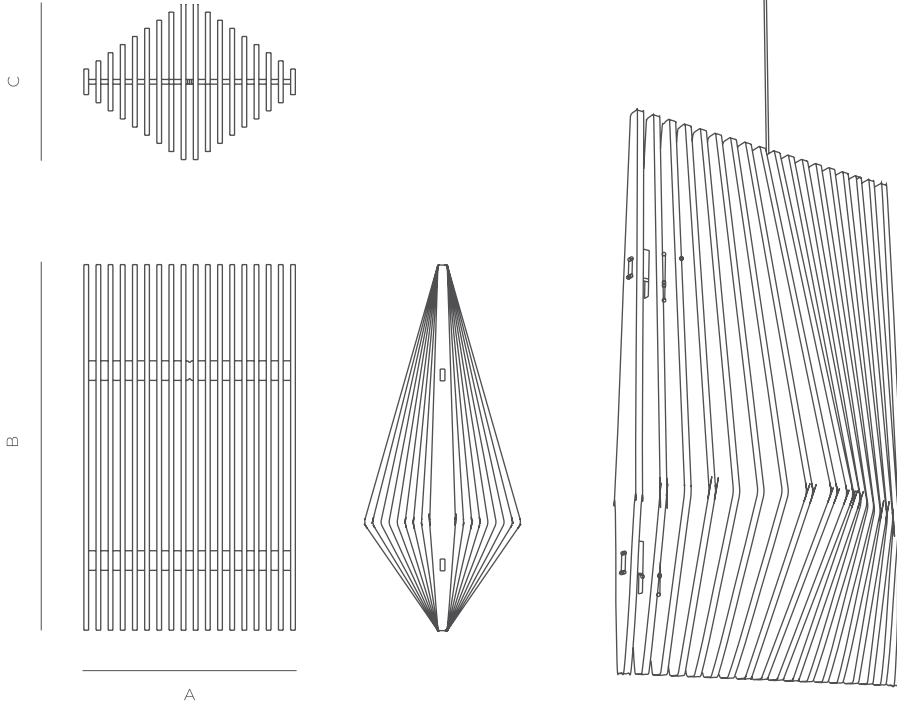

Design *_Diseño:* MOJA Design.



FOCUS OPEN 2024
Baden-Württemberg
International Design Award
Silver

A x B x C: 540 x 930 x 395 mm

KITE

SKU# DBHA0170

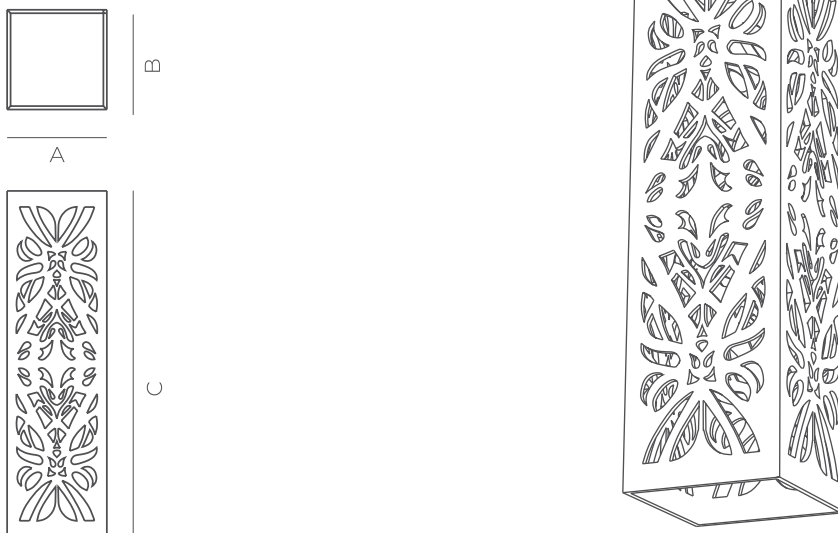

Design *_Diseño:* Elena Mas Parres.

A x B: 347 x 347 mm
C: 1200 mm

PACK
2 uds 347 x 347 x 1200 mm

DROP CEILINGS *TECHOS REGISTRABLES*

AITANA

SKU# DBHA0166

Design *_Diseño:* JC de la Morena.

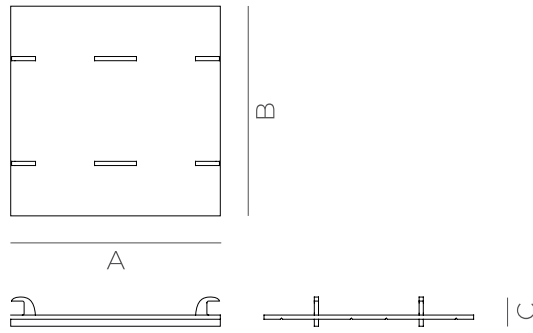
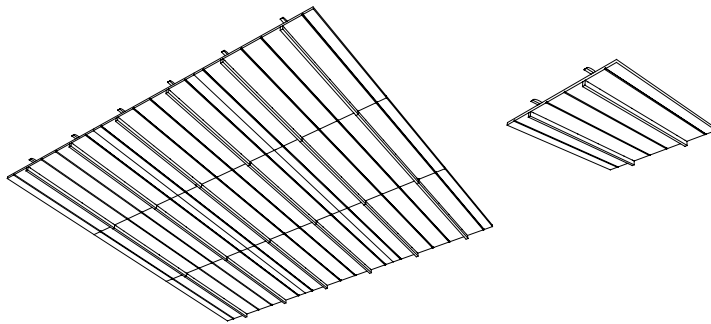

A x B: 595 x 595 mm
C: 84 mm

QUBIC

SKU# DBHA0238

Design *_Diseño:* JC de la Morena.

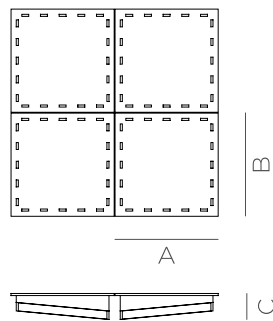
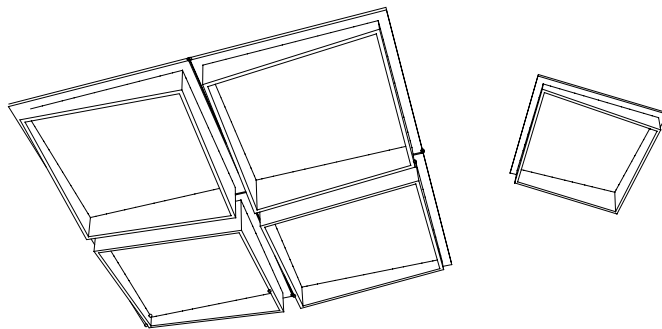

A x B x C: 595 x 595 x 135 mm



Sensitive reliefs that transform acoustics into art.

Relieves sensibles que transforman la acústica en arte.

Wall creations *Creaciones para pared*

These **wall creations** reinterpret acoustic treatment as relief art, adding volume, dynamism and a unique presence. Their three-dimensional shapes soften reverberation while enriching the visual composition of the space. Made from recyclable PET, they offer sustainability, texture and contemporary design. An elegant way to transform walls into living, emotional surfaces.

*Las **creaciones para pared** reinterpretan el tratamiento acústico como arte en relieve, aportando volumen, dinamismo y una presencia única. Sus formas tridimensionales suavizan la reverberación mientras enriquecen la composición visual del espacio. Fabricadas en PET reciclable, aportan sostenibilidad, textura y diseño contemporáneo. Una manera elegante de transformar muros en superficies vivas y emocionales.*



COMFY

SKU# DBHA0168

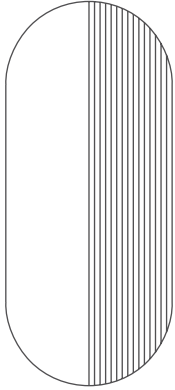
Design *_Diseño:* Nerea Orenes.

1200 x 2780 mm

ASTEROID

SKU# DBHA0239

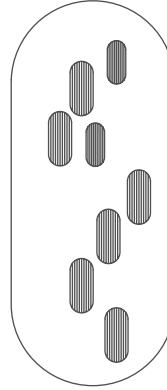
Design *_Diseño:* MOJA Design.

1180 x 2780 mm

HEXAGON

SKU# DBHA0041

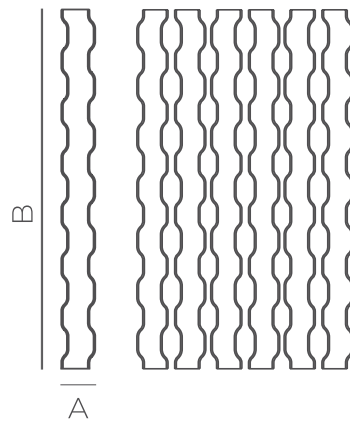
Design *_Diseño:* MOJA Design.

A x B: 235 x 2566 mm

PACK

6 uds 235 x 2566 mm

GINKO

SKU# DBHA0064

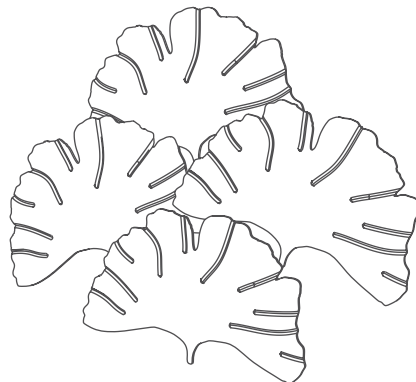
Design *_Diseño:* MOJA Design.

A x B: 1180 x 2780 mm

PACK

4 uds 1110 x 700 mm

MORPH ROUNDED

SKU# DBHA0015

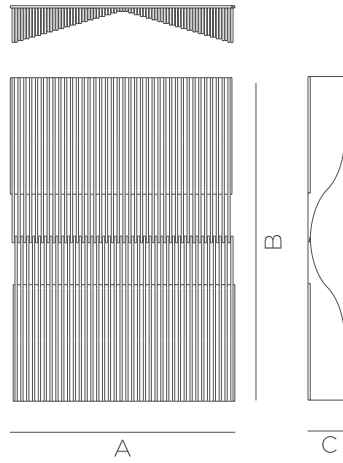

Design _Diseño: MOJA Design.

A: 1180 mm
B: 1500 / 1760 mm
C: 195 mm

SCALES

SKU# DBHA0113

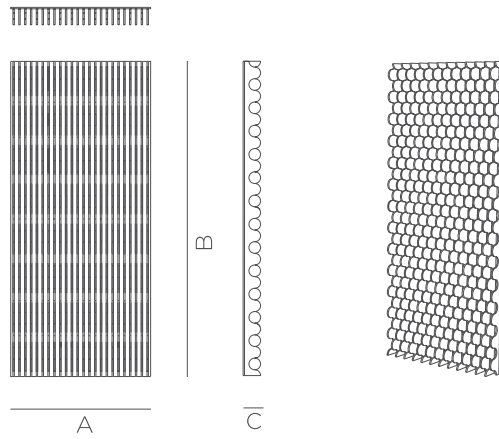

Design _Diseño: MOJA Design.

A: 1200 mm
B: 2700 mm
C: 150 mm

PURE

SKU# DBHA0106

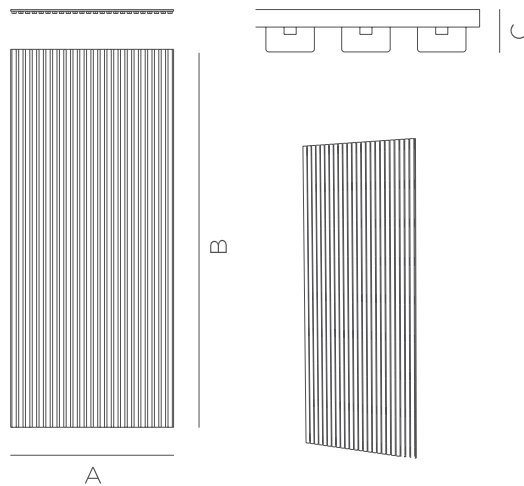

Design _Diseño: JC de la Morena.

A: 1200 mm
B: 2780 mm
C: 29 mm

MORPH SOFT EDGE

SKU# DBHA0065

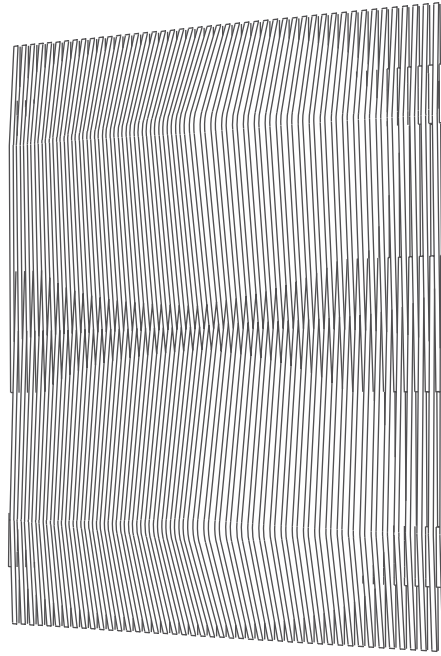
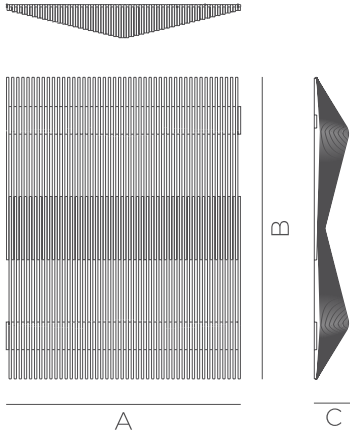

Design _Diseño: MOJA Design.



FOCUS OPEN 2024
Baden-Württemberg
International Design Award
Silver

A: 1180 mm

B: 1220 / 1763 mm

C: 170 mm

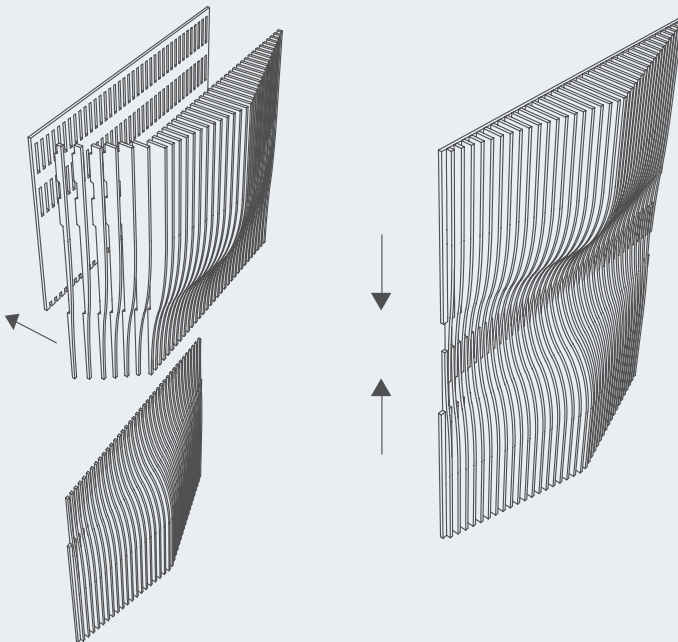
ASSEMBLY MONTAJE

As it is a self-supporting system, the slats easily fit into the wall combs. Their design allows for easy transport and simple assembly of the modules, while installation takes just a few minutes. The height of the assembly is adjustable.

Al tratarse de un sistema autoportante, las lamas se encajan fácilmente en los peines de la pared. Su diseño permite un fácil transporte y un sencillo montaje de los módulos; mientras que su instalación se hace en pocos minutos. La altura del conjunto es regulable.



Expressive pieces that harmonise with pure beauty.

Piezas expresivas que armonizan con pura belleza.

Decorative creations *Creaciones decorativas*

These **decorative creations** combine playful design and acoustic functionality, bringing a distinctive and expressive touch to any space. With organic geometries and a friendly aesthetic, they reduce noise while decorating with intention. Made from recyclable PET, they are environmentally conscious and sustainable pieces. A perfect fusion of art, nature and acoustic well-being.

*Las **creaciones decorativas** combinan diseño lúdico y funcionalidad acústica, aportando un toque distintivo y expresivo al espacio. Con geometrías orgánicas y una estética amable, reducen el ruido mientras decoran con intención. Elaboradas en PET reciclable, son piezas sensibles al entorno y a la sostenibilidad. Una fusión perfecta entre arte, naturaleza y bienestar sonoro.*



Absotec®



FLORA

L: SKU# DBHA0043
S: SKU# DBHA0110

Design *_Diseño:* MOJA Design.

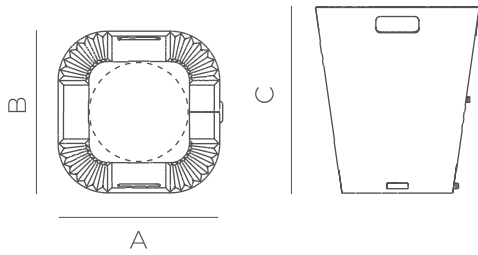
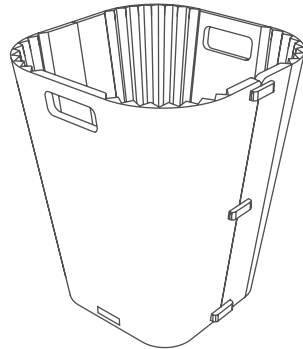

A x B x C: 298 x 298 x 404 / 325 x 325 x 300 mm

PACKS

L: 5 uds 298 x 298 x 404 mm

S: 6 uds 325 x 325 x 300 mm

CACTUS

SKU# DBHA0169

Design *_Diseño:* Clara Sullà.

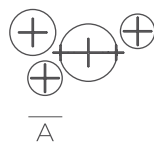
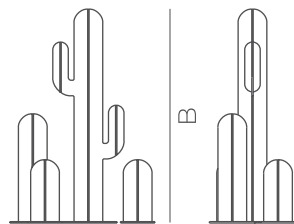
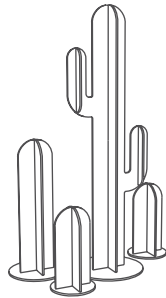

A: 500 / 400 / 300 mm

B: 1862 / 950 / 550 mm

PACK

1 ud Ø500 x 1862 mm

+ 1 ud Ø400 x 950 mm

+ 2 uds Ø300 x 550 mm



Av. Benelux, 91
03600, Elda-Alicante

T. 965 39 40 11
info@harmonium.design

www.harmonium.design

